

DI-1120 Low-cost USB Data Acquisition (DAQ) System

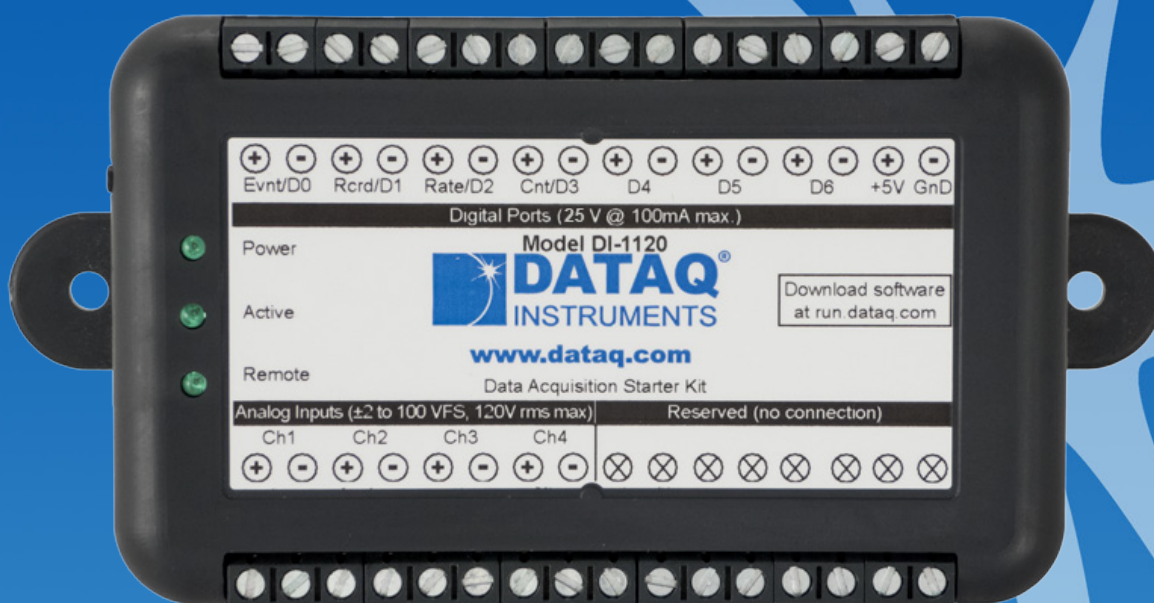

- ✓ Four armored analog differential inputs
 - ✓ Programmable range per channel: $\pm 2, 5, 10, 20, 50, 100$ V full scale
 - ✓ Up to 120 V rms without damage
 - ✓ 50 dB common mode rejection
- ✓ Supports ChannelStretch™ multi-unit synchronization
- ✓ Adaptable low-pass filter per channel
 - ✓ Corner frequency set as a function of sampling rate
- ✓ 14-bit analog-to-digital resolution
- ✓ 160 kHz sample throughput rate
- ✓ Seven digital ports
 - ✓ Programmable per port as input or switch
 - ✓ Support for rate measurements to 50 kHz
 - ✓ Support for 16-bit counter
- ✓ Wide-ranging software support includes:
 - ✓ Ready-to-run WinDaq software
 - ✓ .NET Class for Visual Studio program development
 - ✓ Published protocol for software development in non-Windows operating systems

DI-1120 Description

Overview

The DI-1120 is a new release in a long line of low-cost starter kits from DATAQ Instruments, and an updated and improved replacement for model DI-155 starter kit. Suitable for measuring a wide range of analog signal levels, the DI-1120, in tandem with the included WinDaq software, allows real time data acquisition, playback, and analysis performance that covers an incredibly broad array of measurements in both laboratory and industrial settings.

Analog Subsystem

Model DI-1120 delivers premium analog performance at a surprisingly affordable price. Four analog input channels provide differential measurement flexibility and programmable ranges per channel of ± 2 , ± 5 , ± 10 , ± 20 , ± 50 , and ± 100 V full scale. The differential input configuration provides noise rejection, easily adapts to single-ended signal sources, and is protected to 120 V rms so that inevitable measurement mishaps will not harm the instrument. The front end feeds a variable resolution, 14-bit ADC that ranges from 12 to 14 bits as a function of sampling rate. Lower sampling rates deliver higher resolution readings. The maximum sampling throughput rate of the DI-1120 is 160 kHz, providing 12 bits of resolution. Below 40 kHz the instrument provides 14-bit measurement resolution. Rounding off the analog subsystem are low-pass filters per channel with automatic corner frequency selection as a function of sampling rate. All these features combine to provide pure data acquisition power at an unmatched price point.

Digital I/O Subsystem

The DI-1120 provides 7 digital ports, each configurable as an input or a switch. Input protection is provided to 25 V. When activated as inputs two ports allow dual functionality as discrete inputs, or can be programmed as a counter or rate input respectively. The rate input features a 50 kHz maximum measurement, allocated over twelve programmable measurement ranges (10 Hz to 50 kHz full scale.) The counter input provides 16-bit resolution and a terminal count value of 65,535. The discrete, counter, and rate inputs are members of the same internal scan list used by the analog input channels. This means that all enabled elements are acquired synchronously, which allows meaningful comparisons between analog and digital channels. For example, the rate input measuring engine speed allows rpm data to be acquired in lock-step with analog data. Configured as a switch a digital port can be used to control external loads up to 25 V @ 100 mA, and the switch can be controlled asynchronously during scanning.

Software Overview

Model DI-1120 starter kit is provided with comprehensive software support. For point-and-click, ready-to-run applications the DI-1120 is supplied with our popular WinDaq software. WinDaq allows a real time display of any combination of analog channels, and the ability to stream acquired data to disk in recorder-like fashion, even at the fastest rate supported by the hardware. This is true streaming performance, continuous, without gaps, and simultaneously to both the real time display and disk. Record only a few readings, or as many as 4 GB. The DI-1120 reserves two digital inputs for WinDaq software that are dedicated for remote stop/start and remote event operations. WinDaq also includes software to review recorded data files, including waveform analysis and data file export to Microsoft Excel and other applications. Custom programming the DI-1120 is supported through its .Net class and protocol documentation. Finally, the DI-1120's unique ChannelStretch™ technology allows multiple instruments to be synchronized to expand channel count without clumsy external cabling (details inside).

DI-1120 Close-up

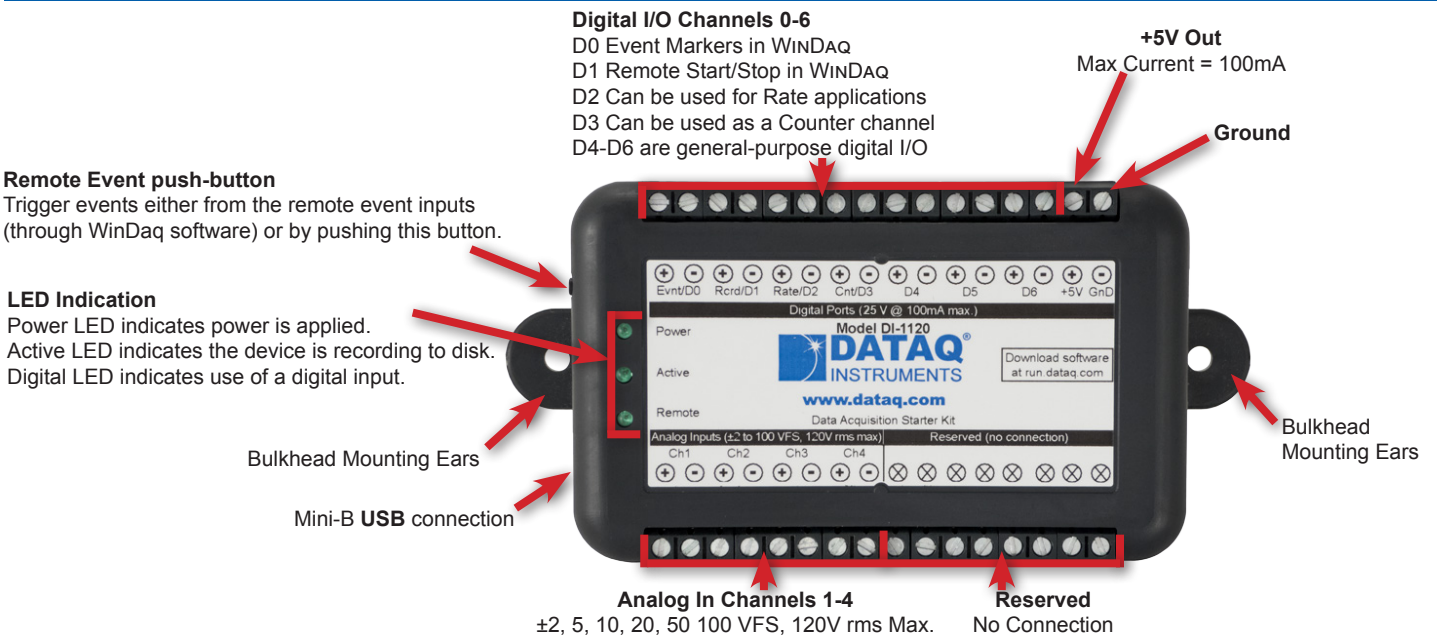

DI-1120 Major Features and Benefits

Four Analog Input Channels

Measure as many as four system variables at once with programmable ranges per channel of ± 2 , ± 5 , ± 10 , ± 20 , ± 50 , and ± 100 V full scale.

Differential Analog Input Configuration

Enhanced noise immunity and tolerance of common mode voltages.

12- to 14-bit Measurement Resolution

One product addresses your measurement needs, from low to high resolution, as a function of sampling rate.

Armored Inputs Absorb Mistakes

Both analog and digital inputs are protected to 120 Vrms and 0-25 V dc respectively.

Fast 160 kHz Sample Throughput Rate

Observe fast phenomena that other products in the DI-1120's price range would miss.

Comprehensive Programming Support

The instrument is offered with a comprehensive .Net class for the Windows programming environment. Its device protocol is fully documented for use with operating systems other than Windows.

Supports ChannelStretch™ Channel Expansion

Connect as many as sixteen DI-1120s to one PC. Synchronously acquire from as many as 64 and 112 analog and digital channels respectively.

Seven Digital Input Ports

Folds discrete I/O into the measurements process. Each bit is programmable as an input or as a switch and protected to 0-25 V dc.

Asynchronous Digital Switches

Control external processes seamlessly while acquiring data.

Counter Channel

Tallies the number of pulses applied. Useful for integrating rate information, like flow rate to volume, or simply the number of definable events.

Rate Measurement Channel

Measures pulse rate where frequency carries information. For example rpm or flow measurements.

Ready-to-run Software Support

Provided with ready-to-run WinDaq software for point-and-click DAQ performance with a real-time display, disk-streaming recording, and playback and analysis.

DI-1120 Dimensional Drawing

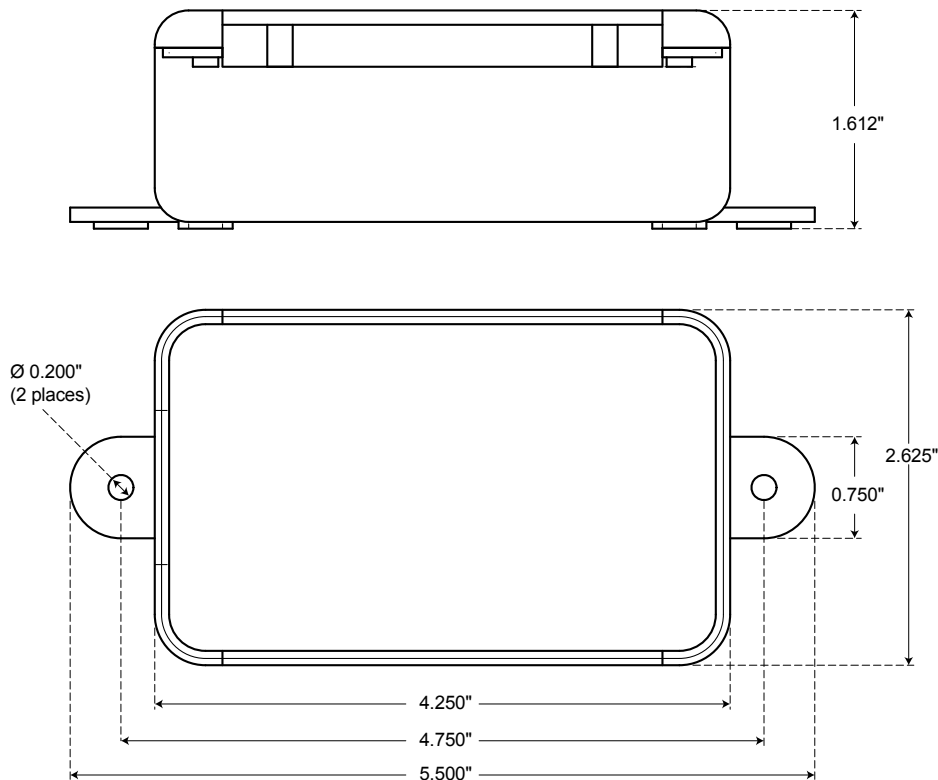

Analog-to-digital Converter Characteristics

DI-1120 ADC resolution is a function of sampling rate: Slower sampling rates yield higher resolution measurements. The DI-1120 achieves this using its real time CIC decimation filter to improve signal-to-noise ratio and to increase measurement resolution. Before the DI-1120 such techniques were reserved only for high-end instrumentation because of the cost of processing power required to provide meaningful, multi-channel results in real time. But that cost has been driven down dramatically so that the 120 MIPS processor embedded in the DI-1120 is both affordable and more than adequate for the task.

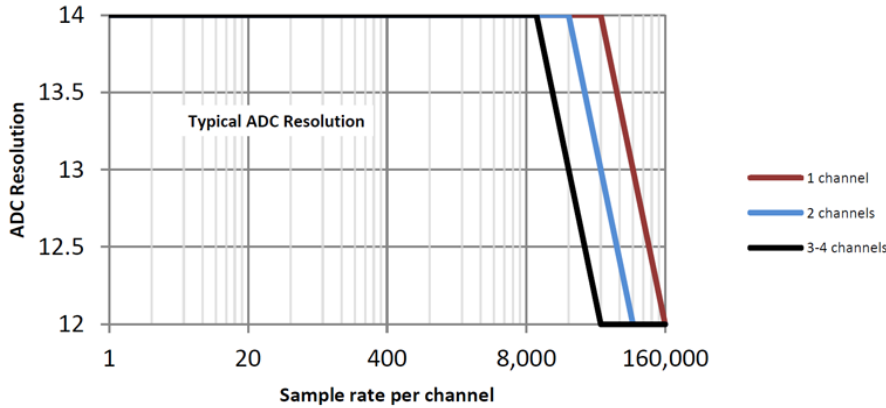

ADC resolution (R) is a function of selected sample rate per channel (F), and the number of enabled analog channels (C):

$$R = \frac{\log_{10} \left(\frac{160000}{FC} \right)}{\log_{10}(2)} + 12$$

Where:

C	Enabled Channels
1	1
2	2
4	3-4

Synchronize Multiple DI-1120s with ChannelStretch™ Technology

Need more channels? Add another unit. Add up to fifteen more for a total of 64 analog channels and 112 digital ports to a maximum throughput rate ≥ 480 kHz using the DI-1120's ChannelStretch™ technology. Multiple DI-1120s connected to the same USB hub automatically synchronize to within 10 μ s between units. If you need more USB ports to accommodate more DI-1120 units, simply cascade multiple USB hubs to expand port count. Best of all, when using WinDaq software the enabled channels of all synced units flow into the same WinDaq application. They're displayed and stored together as though they all originated from a single instrument. Synchronized instruments must have the same sample rate per channel regardless of channel type and gain factor. The WinDaq/Unlock option per instrument is required to synchronize DI-1120s when using WinDaq software.

ChannelStretch™ Technology

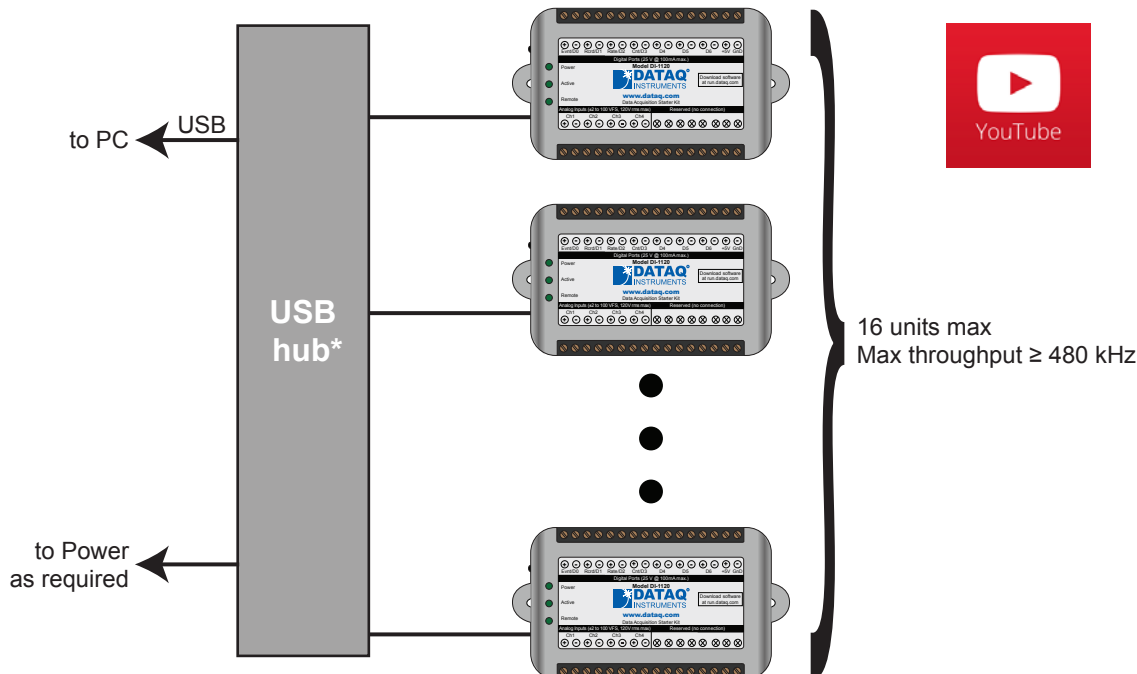

*DATAQ Instruments 7-port USB hub (part number 2000310). Cascade for a higher port count.

DI-1120 Analog Measurements

Four analog input channels each with a programmable measurement range of $\pm 2, 5, 10, 20, 50, 100$ V full scale are supported by the DI-1120. Though not isolated inputs, each offers differential input capability with some rejection of common mode voltages (those that appear simultaneously and in-phase on both inputs). These channels are also hardened to tolerate excessive voltages to protect against wiring mishaps.

Traditional Chart Recorder Replacement

Digitize and record measurements from instruments with high-level analog outputs.

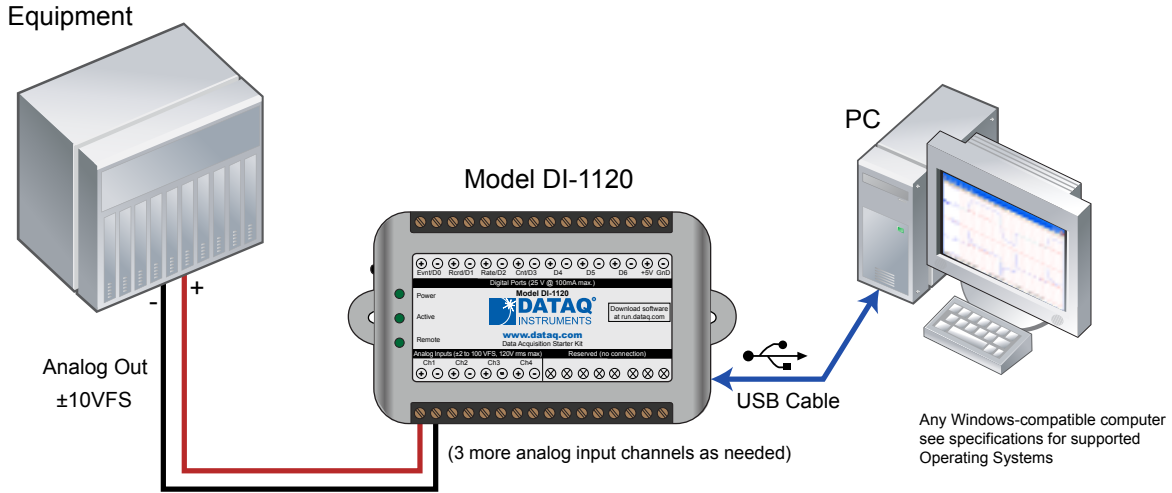

Examples of "Equipment" above include gas chromatographs, liquid chromatographs, spectrometers, bio-amplifiers*, etc.

* DATAQ Instruments' hardware and software products are NOT designed to be used in the diagnosis and treatment of humans, nor are they to be used as critical components in any life support systems whose failure to perform can reasonably be expected to cause injury to humans.

Process Monitoring

Trend plot and record control and feedback signals to troubleshoot process glitches.

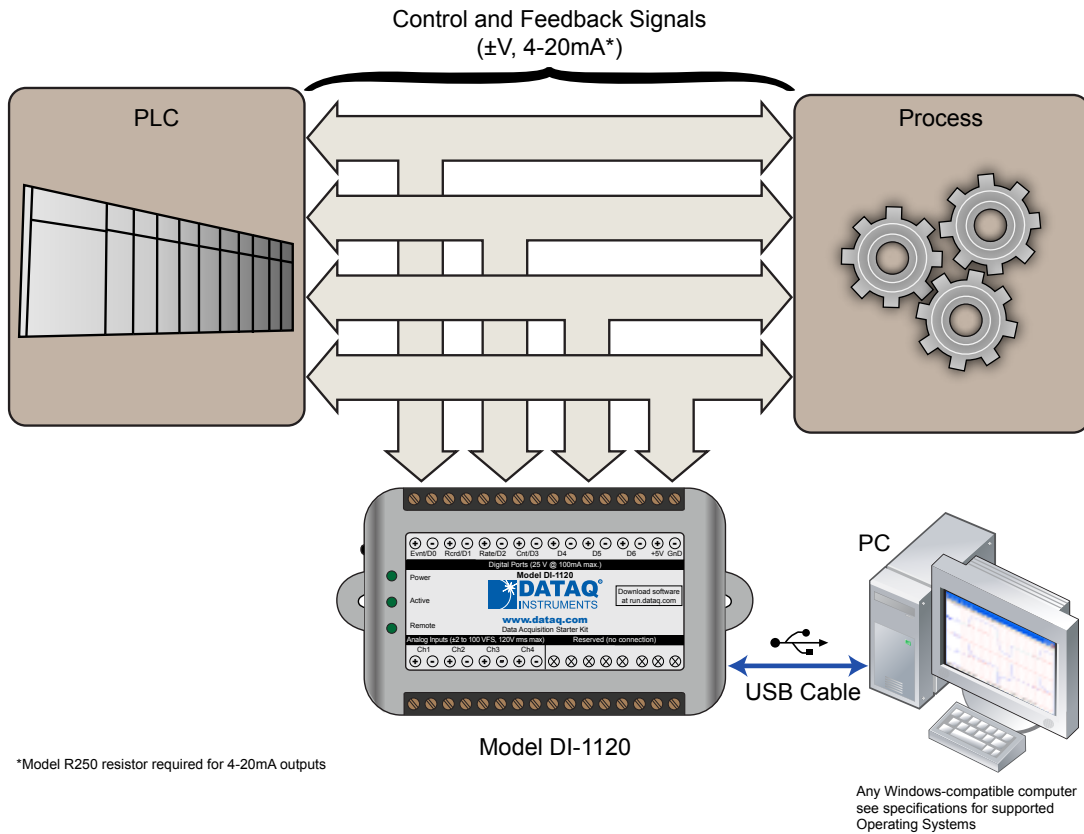

*Model R250 resistor required for 4-20mA outputs

Typical Analog Measurements

4-20mA current (low-side shunt)

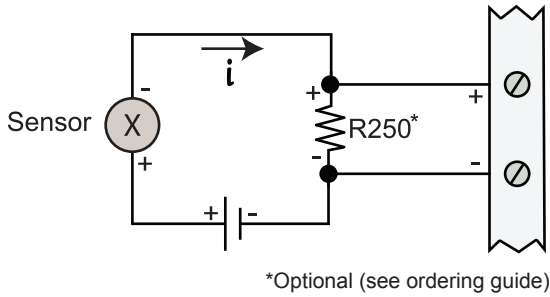

Voltage source

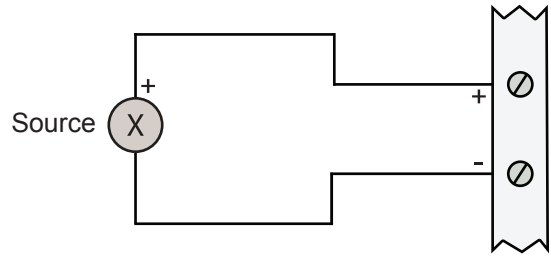

General-purpose Digital Port Operation

Each DI-1120 digital port can be configured as a digital input or used as a switch to control an external load. Ports are configured by a MOSFET that defines the port's function, where the MOSFET is either on or off. When the MOSFET is off the port is available as a discrete input. Turning the MOSFET on allows the port to function like a switch for loads up to 25 V and 100 mA. Care should be exercised when configuring the load to be switched to ensure that the digital port is not damaged:

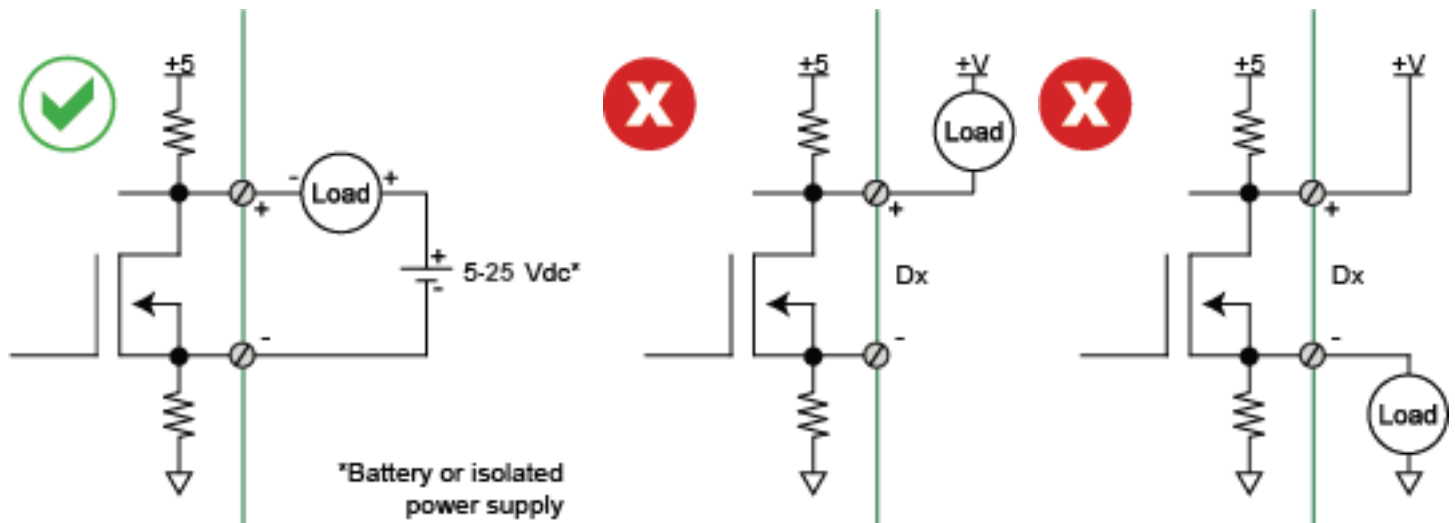

DI-1120 Rate and Count Measurements

Digital ports D2 and D3 can be programmed for multiple functions. Both can be programmed as discrete inputs or outputs. In addition, port D2 can be programmed as a rate input and port D3 as a counter input. When programmed to measure rate and/or count the DI-1120 adds these measurements to its internal scan list along with any other analog or digital data so that all measurements are acquired in the same time frame. Rate measurements in the range of 10 Hz to 50 kHz are possible across twelve programmable full scale ranges. Use the rate input to extract rpm data from a rotating device, or to acquire flow information from a pulse-type flow sensor. Count measurements up to 65,536 are supported by the D3 port. Use count to integrate flow to get volume, or use it simply to tally events in a given process.

Rpm from rate

The DI-1120's Rate input is used to acquire a frequency representing rpm, flow, or any other pulse stream.

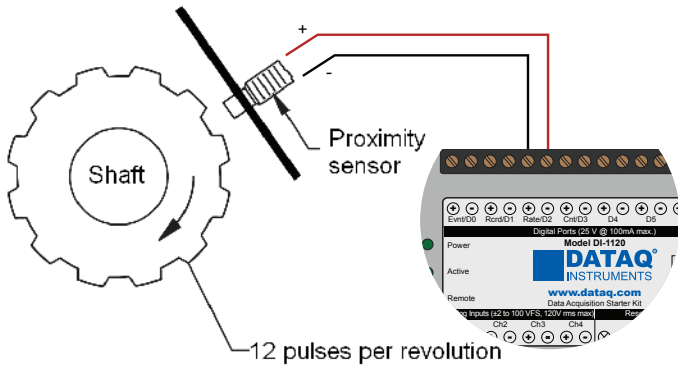

Flow/volume

Use the DI-1120's Count input to accumulate a tally of applied discrete pulses to track test cycles, extract volume from flow, or any other general-purpose totalizing application.

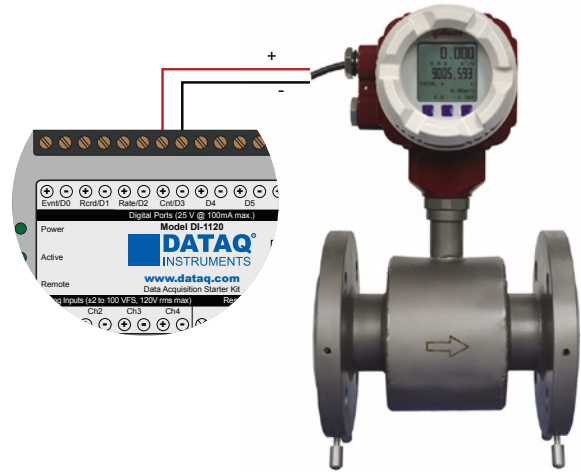

Remote Control Close Up

The DI-1120 supports several methods to increase measurement flexibility and data record interpretation. The remote record feature allows you to synchronize WinDaq recordings to external processes by remotely enabling and disabling WinDaq's stream-to-disk feature. Remote events allow you to insert an event marker in the data stream (see inset) to identify when an event occurred relative to recorded waveform activity. Events can be activated by the pushbutton on the DI-1120 enclosure, though a keyboard keystroke (which also allows you to record a description), or remotely via the remote event input. The stream-to-disk function can also be controlled through the keyboard, or through the remote record input. Valid remote record and event signals are switch closures, or discrete levels with a maximum input of 25 V. Finally, each port is internally pulled-up, so it's easy to use with external dry-contact switches.

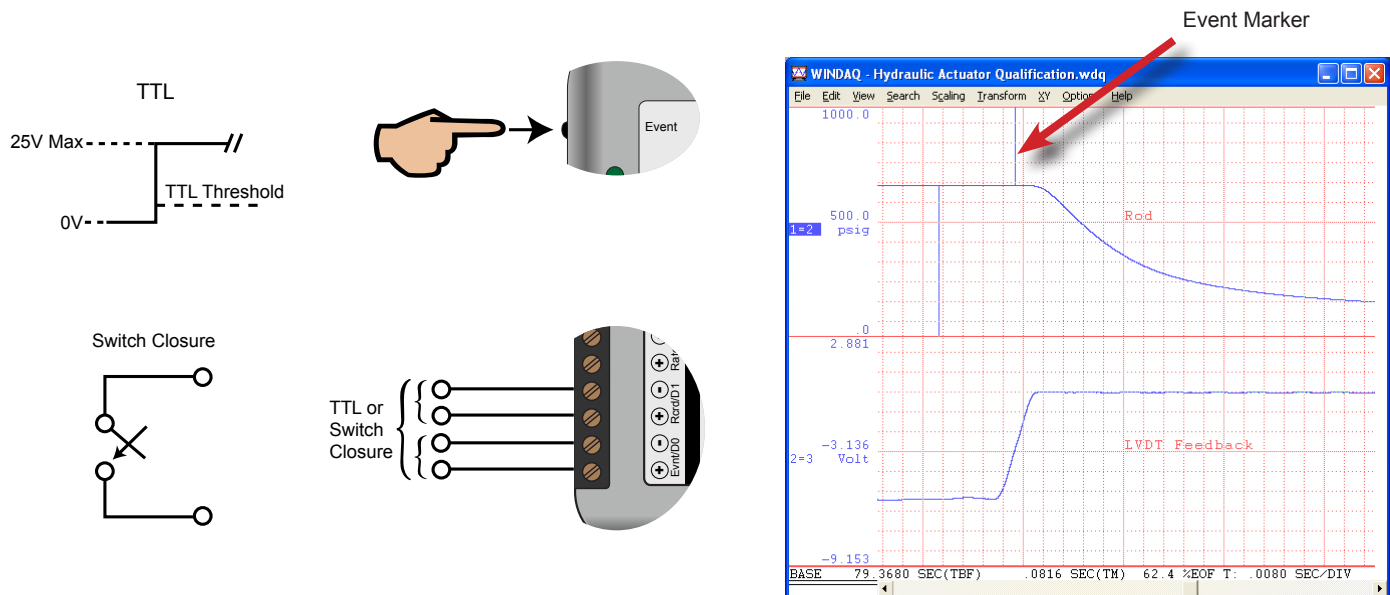

Setup

Double-click and enter the channels you want to acquire into the WINDAQ scan list. Click to select signal averaging, true RMS, frequency, and peak or valley detection per channel. Click to define a single to 4-channel display — either triggered sweep (oscilloscope-like) or scrolling (chart recorder-like). Click again to define a sample rate ranging from 20 Hz to 160 kHz throughput per device.

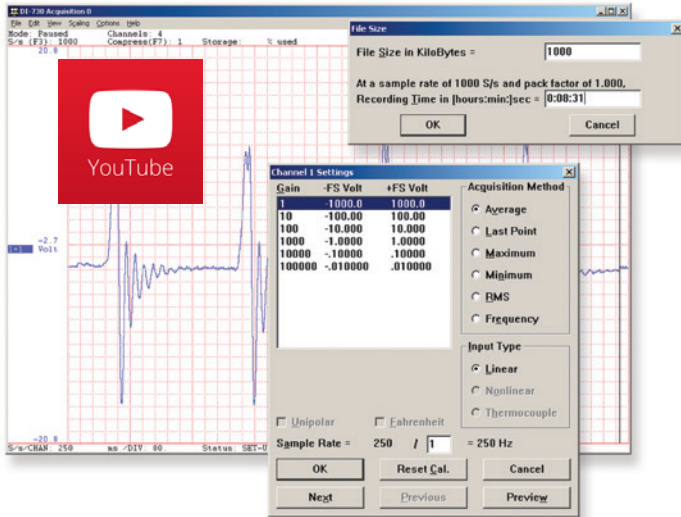

Calibrate

Define calibration per channel to display waveform values in meaningful units such as psi, °F or °C, amps, rpm, watts, horsepower — any unit of measure you need.

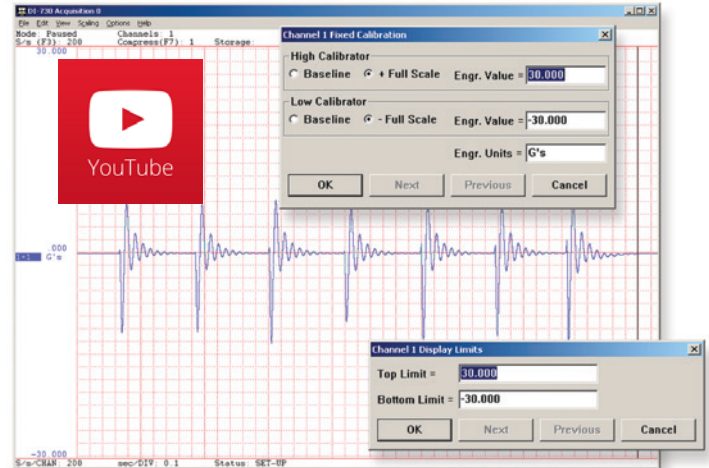

Record

Choose a continuous waveform recording mode or the triggered mode with selectable trigger level, slope, and post-trigger times. WINDAQ automatically time- and date-stamps, then streams acquired data to disk — record as much data as you need. At the same time, WINDAQ supplies a real-time graphical display of any or all channels so you always know where you are and where you're going.

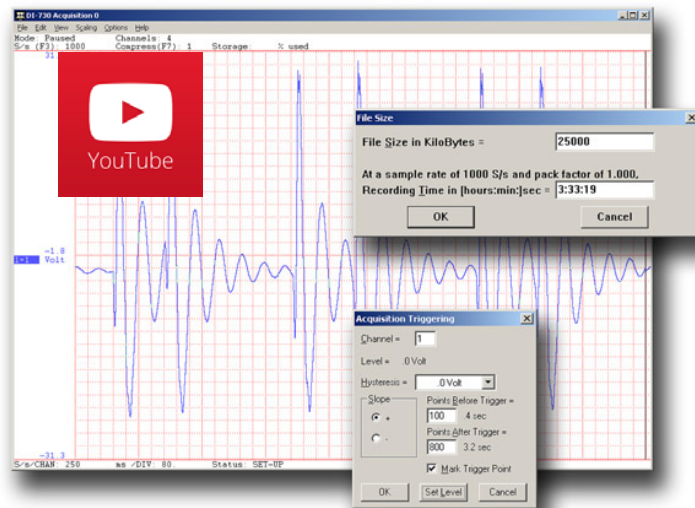

Annotate

Of course, you can label any channel with text that describes it — “Motor 1,” “Engine speed,” “Vertical position,” etc. But WINDAQ also allows you to supply commented event markers while you record — “Beginning test phase 1,” “Small vibrations noticed,” “Starting cool-down cycle,” etc. Your comments and our acquired data combine to form a complete diary of your data acquisition session.

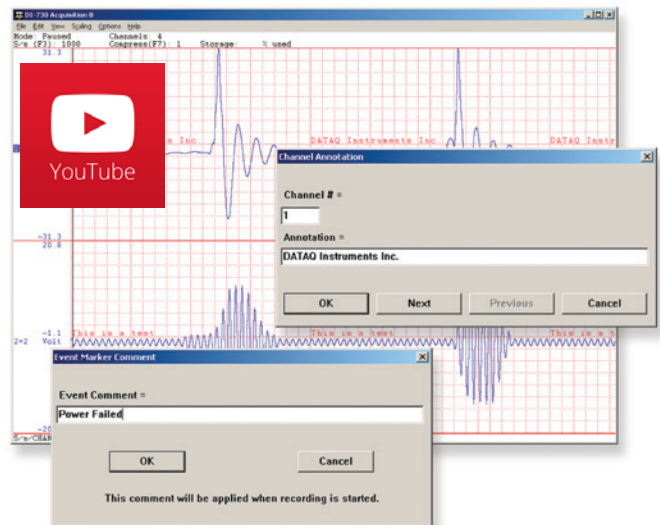

Playback

Recording is only half the solution. WINDAQ's Waveform Browser playback software allows you to graphically manipulate waveforms in ways you've never seen on a PC. Compress an entire recording to one screen-width for a bird's eye view, then expand around an area of interest for a closer look. Use the cursor to measure amplitudes and timing with precision. Move to any event marker with the click of a mouse button.



Multitask

Double your productivity and let WINDAQ record while you review last week's results from your spreadsheet, or compose a memo with your word processor. You can even play back data already stored to disk while you're still recording.

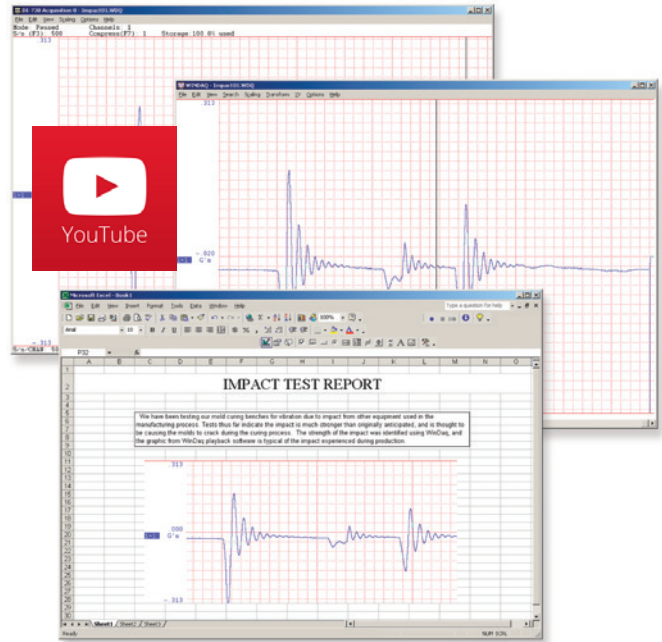

Analyze

Waveform interpretation is easy with our built-in analysis functions. Apply frequency and filtering analysis with the WINDAQ Waveform Browser FFT and DFT functions. Analyze any range of waveform data with the statistics function. Use X-Y plotting to examine the relationship of one channel to another. Optional Advanced CODAS analysis functions allow waveform peak detection, integration, differentiation, arithmetic operations, and more.

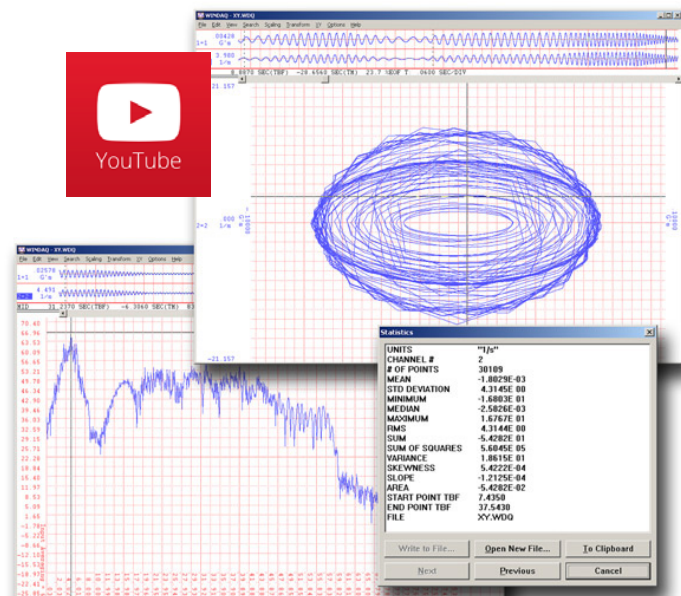

Export

The WINDAQ Waveform Browser can export any range of data to your spreadsheet, or any other analysis or presentation package you use. You can even copy a graphical image displayed by the WINDAQ Waveform Browser and paste it directly into a word processing document. Finally, export any range of waveform graphics to your printer for a hard copy record.

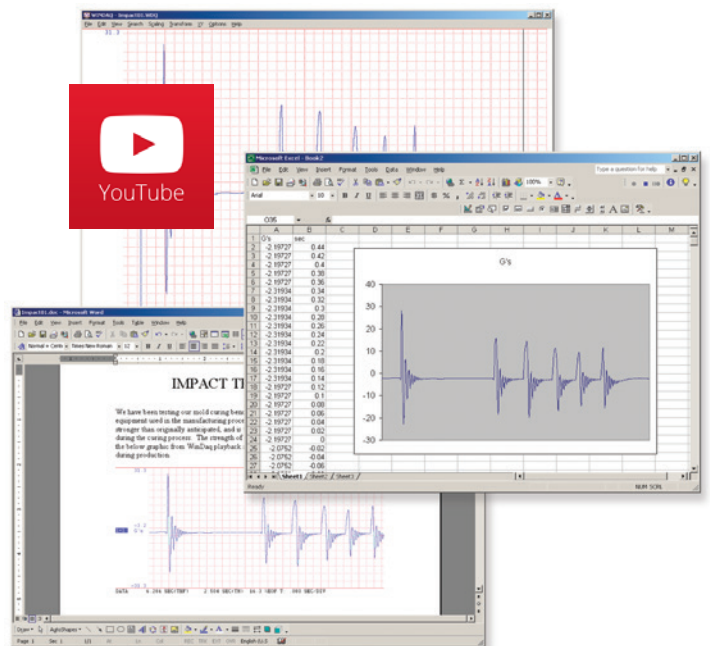

Four Analog Channel Reporting Modes

The DI-1120 can be configured per channel to report just the last sample acquired like other data acquisition products. Unlike other products three additional reporting modes, selectable per analog channel, provide much more flexibility when reporting oversampled data:

Anti-alias filter

Oversampled data is passed through the DI-1120's anti-alias CIC filter. Use this mode to dramatically reduce the unwanted effects of alias frequencies and noise.

Maximum value

Oversampled data is evaluated for the maximum value. Use Maximum to peak-detect complex waveforms.

Minimum value

Oversampled data is evaluated for the minimum value. Use Minimum to valley-detect complex waveforms.

All four operating modes are supported by WinDaq software. And, since they are applied by DI-1120 firmware, custom programs can easily leverage these features without incremental programming overhead.

Published Protocol and .Net Class

Sometimes you can't use a ready-to-run application like WinDaq. You need to develop your own software to perform in precisely the way you need. That requirement defines the need for programming support so you have the tools necessary to move forward.

Included .NET Class

Microsoft's object-oriented programming languages commonly referred to as .NET ("Dot Net") offer a powerful environment for developing custom applications for the DI-1120. All of the .NET languages are supported by our included class library, which supports all DI-1120 features. Well commented example programs exercise every aspect of the hardware, forming a foundation for you to get your own applications up and running quickly and painlessly.

Included DI-1120 Protocol Documentation

As you probably suspect when you run our point-and-click WinDaq data acquisition software, there's a lot going on beneath the surface. WinDaq software needs to take the data acquisition configuration that you design using its menu system and communicate that to the hardware. These are things such as sample rate, the number of channels enabled, the specific channel numbers enabled, etc. Diving down to the lowest level of program activity, past the WinDaq user interface, beyond the device driver to the actual commands sent to the data acquisition hardware and the format of the responses they evoke, is the protocol. The protocol defines the exact set of commands a program can send to the hardware, and how the hardware will react as a result. So, if you know the command and response definitions for the DI-1120 (i.e., its protocol), the instrument can be folded into virtually any operating system and any programming language: Python, C++, Linux, Windows, OSX, etc., etc. The choice is yours.

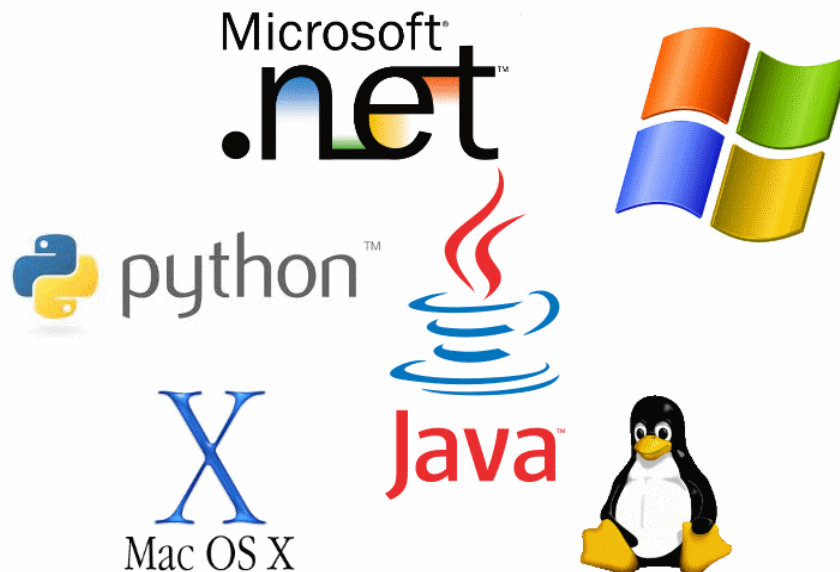

DI-1120 Specifications

Analog Inputs

Number of Channels: 4
 Configuration: Differential
 Full Scale Range: $\pm 2, 5, 10, 20, 50, 100$ V full scale
 Input impedance: 795 k Ω
 Absolute accuracy: 0.25% of full scale range
 @ 25°C, excluding common mode error
 Absolute maximum input without damage: 120 V rms (normal mode + common mode)
 Maximum common mode voltage: 120 V rms
 Common mode range: ± 20 V dc or peak ac
 Common mode rejection ratio: 50 dB (dc - 60 Hz)
 Channel-to-channel crosstalk rejection: -80 dB

Digital Inputs

Total port count: 7
 Type: MOSFET switch
 Threshold levels: TTL-compatible
 Absolute maximum applied voltage (V): 25 V dc

Digital Ports

Total port count: 7

Programmed as a Switch

Maximum drain voltage: 25 V
 Maximum sink current: 100 mA

Count/Rate/Inputs

Internal pull-up value: 4.7 k Ω
 Input high voltage threshold: 2.4 V
 Input low voltage threshold: 0.8 V
 Terminal count: 65,535
 Maximum rate frequency: 50 KHz with one enabled channel, 20 KHz with 2-4 enabled channels, 10 KHz with 5-7 enabled channels
 Minimum rate frequency: 0.5 Hz
 Maximum count frequency: 50 kHz

Reserved Digital Inputs

D0: WinDaq remote events
 D1: WinDaq remote start/stop
 D2: Rate input
 D3: Count input

ADC Characteristics

Resolution: 12- to 14-bit
 Above zero ADC counts: 2,047 to 8,191
 Below zero ADC counts: 2,048 to 8,192
 Maximum sample throughput: 160 kHz
 Minimum sample throughput: 20 Hz (2.2 samples per hour with WinDaq)
 Sample rate timing accuracy: 50 ppm

Indicators and Connections

Interface: USB 2.0 (mini-B style connector)
 Indicator lights: 3 LEDs
 Input Connections: Two 16-position terminal strips

ChannelStretch™ Operation

Maximum number of DI-1120 units: 16
 Maximum channel count: 64 analog, 112 digital
 Maximum supported throughput: ≥ 480 kHz
 Synchronization conditions: All instruments must be configured for the same sample rate per channel, ≤ 20 kHz. Enabled channels per instrument are independent of measurement function and range.
 PC USB prerequisite: All instruments must be connected to the same USB controller. The use of USB hubs are recommended to meet this requirement.

Power

Power Consumption: <1.0 Watt, via USB interface

Environmental

Operating Temperature: 0 to 50 °C
 Operating Humidity: 0 to 90% RH non-condensing
 Storage Temperature: -20 to 60 °C
 Storage Humidity: 0 to 90% non-condensing

Physical Characteristics

Enclosure: Hardened Plastic
 Mounting: Desktop; bulkhead
 Dimensions: 2.625D \times 5.5W \times 1.53H in. (6.67D \times 13.97W \times 3.89H cm.)
 Weight: 5.7 oz.

Software Support

WINDAQ software: OS support: View Online (<https://www.dataq.com/products/windaq/windows-compatibility/>)
 Programming: DATAQ .NET Class, Instrument protocol, ActiveX Control

Ordering Guide

Description	Order No.
DI-1120 USB Data Acquisition (DAQ) System Includes instrument, 6-ft. USB cable, screwdriver, and WinDaq software via Internet download (run.dataq.com)	DI-1120
250Ω 4-20 mA shunt resistor $\pm 0.1\%$, 0.5 Watts max., ± 50 ppm/°C	R250



241 Springside Drive
 Akron, Ohio 44333
 Phone: 330-668-1444
 Fax: 330-666-5434

Data Acquisition Product Links

(click on text to jump to page)
[Data Acquisition](#) | [Data Logger](#)