

# NSM-208-M12 *NEW*

EN50155 8-port M12 Unmanaged Ethernet Switch

# NSM-208PSE-M12 *NEW*

EN50155 8-port M12 Unmanaged PoE Ethernet Switch

NSM-208-M12

NSM-208PSE-M12



NSM-208-M12/NSM-208PSE-M12 Series					For NSM-208PSE-M12		For NSM-208-M12	
-40 ~ +75 Wide Temperature	Wall Mount	IP40	EN50155	CE	FCC	+46 ~ +53 Input Voltage	PoE + LAN x 8	LAN x 8

## Features ▶▶▶▶

- Each port supports both 10/100 Mbps speed auto negotiation
- 8 PoE ports with Power Sourcing Equipment (PSE) operation (NSM-208PSE-M12)
- Over-temperature, over-current and over/under-voltage detection (NSM-208PSE-M12)
- 8-port 10/100 Mbps M12 type connector with IP40 protection
- Full duplex IEEE 802.3x and half duplex backpressure flow control
- EN50155-certified for harsh railway standards
- Automatic MDI/MDI-X crossover for plug-and-play
- Store-and-forward architecture
- Auto-detection of PD (powered devices) and automatic power management (NSM-208PSE-M12)
- Supports operating temperatures from -40 °C ~ +75 °C

## Introduction

The NSM-208PSE-M12/NSM-208-M12 is designed for industrial applications in harsh environments. The M12 connectors ensure tight, robust connections, and guarantees reliable operation, even for applications that are subject to high vibration and shock.

The NSM-208PSE-M12 PoE switch provides 8 fast Ethernet M12 ports with 8 IEEE 802.3af compliant PoE ports. The switch is classified as power source equipment (PSE) and provide up to 15.4 W of power per port.

The Ethernet switch supports IEEE 802.3/802.3u/802/3x with 10/100M, full/half-duplex, MDI/MDI-X auto-sensing, and provides an economical solution for your industrial Ethernet network.

The NSM-208-M12 provides a wide +12 V<sub>DC</sub> ~ +53 V<sub>DC</sub> power range to fit all the common power standards found in industrial automation, without external power converters. The wide power input lowers installation and maintenance costs.

## Comparison Table of 8-port M12/IP67 Ethernet Switch

Mode Name	NSM-208PSE-M12	NSM-208-M12	NS-208PSE-IP67	NS-208-IP67
PoE	802.3af x 8	-	802.3af x 8	-
Input Voltage Range	+46 V <sub>DC</sub> ~ +53 V <sub>DC</sub>	+12 V <sub>DC</sub> ~ +53 V <sub>DC</sub>	+46 V <sub>DC</sub> ~ +53 V <sub>DC</sub>	+12 V <sub>DC</sub> ~ +53 V <sub>DC</sub>
Operating Temperature	-40 °C ~ +75 °C	-40 °C ~ +75 °C	-10 °C ~ +60 °C	-10 °C ~ +60 °C
Casing	Metal with IP40	Metal with IP40	Plastic (Flammability UL 94V-0) with IP67	Plastic (Flammability UL 94V-0) with IP67
Installation	Wall Mounting	Wall Mounting	DIN-Rail Mounting or Wall Mounting	DIN-Rail Mounting or Wall Mounting
Dimensions (W x L x H)	190 mm x 56 mm x 100 mm	190 mm x 56 mm x 100 mm	190 mm x 155 mm x 104 mm	190 mm x 155 mm x 104 mm

**Specifications**

Models	NSM-208PSE-M12	NSM-208-M12
<b>Technology</b>		
Standards	IEEE 802.3, 802.3u, 802.3x, 10/100 Base-T(X) auto negotiation speed, F/H duplex mode, and auto MDI/MDI-X connection	
Processing Type	Store & forward	
MAC Addresses	1024	
Memory Bandwidth	3.2 Gbps	
Frame Buffer Memory	512 Kbit	
Flow Control	IEEE 802.3x flow control, back pressure flow control	
<b>Interface</b>		
LED Indicators	PWR, Link/Act, Power Device is detected	PWR, Link/Act
Ethernet Isolation	1500 V <sub>rms</sub> 1 minute	
Connector	Female 4-Pin shielded M12 D-coding connector x 8	
<b>Power Input</b>		
Input Voltage Range	+46 V <sub>dc</sub> ~ +53 V <sub>dc</sub>	+12 V <sub>dc</sub> ~ +53 V <sub>dc</sub>
Power Consumption	0.12 A @ 48 V <sub>dc</sub> without PD loading 3.0 A @ 48 V <sub>dc</sub> with PD full loading	0.12 A @ 48 V <sub>dc</sub>
Protection	Power reverse polarity protection	
Connector	Male 5-Pin shielded M12 A-coding connector x 1	
<b>PoE Technology</b>		
PoE Compliance	100% IEEE 802.3af compliant	-
PoE Classification	PSE (Power Sourcing Equipment)	-
PoE Voltage	+48 V <sub>dc</sub> depending on power input	-
PoE Power	Up to 15.4 W per port	-
PoE Operation	Automatic detection and power management	-
PoE Pin Assignments	V+ (Pin 1, 3), V- (Pin 2, 4)	-
PoE Disconnect Mode	DC disconnect	-
<b>Mechanical</b>		
Casing	Metal with IP40	
Dimensions (W x L x H)	190 mm x 56 mm x 100 mm	
Installation	Wall Mounting	
<b>Environmental</b>		
Operating Temperature	-40 °C ~ +75 °C	
Storage Temperature	-40 °C ~ +85 °C	
Ambient Relative Humidity	10 ~ 95% RH, non-condensing	

**Applications**



# EN50155 8-port M12 Unmanaged Ethernet Switch

- NSM-208-M12
- NSM-208PSE-M12



Wide Range Temperature: -40 °C ~ +75 °C  
EN50155-certified for harsh railway standard



### Appearance

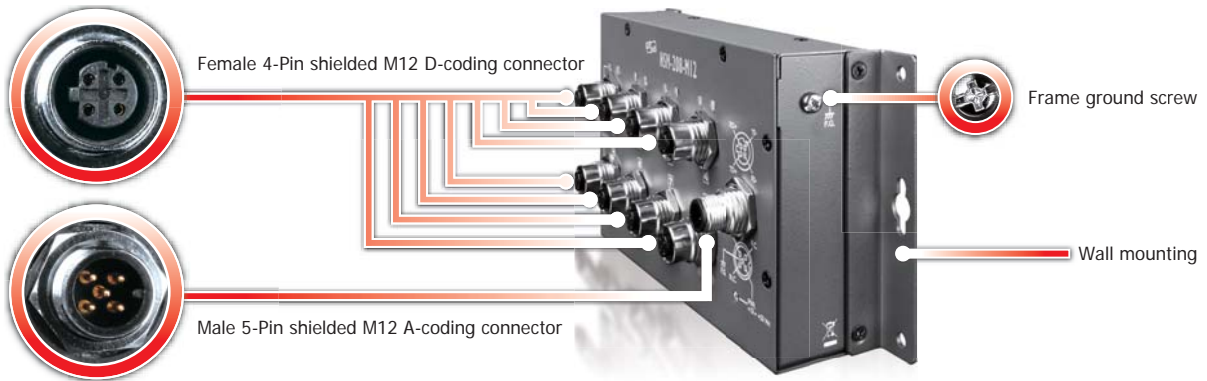

### Pin Functions for Power Input

External power supply is connected using the M12 A-coding:  
 PWR: Power input and should be connected to the power supply (+)  
 GND: Ground and should be connected to the power supply (-)  
 F.G.: F.G. stands for Frame Ground (protective ground). It is optional.  
 If you use this pin, it can reduce EMI radiation; improve EMI performance and EMS protection.

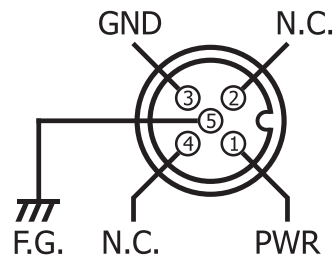

### Pin Functions for Ethernet Port

For NSM-208PSE-M12

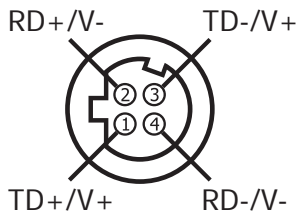

For NSM-208-M12

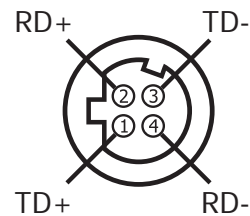

### Dimensions (Units: mm)

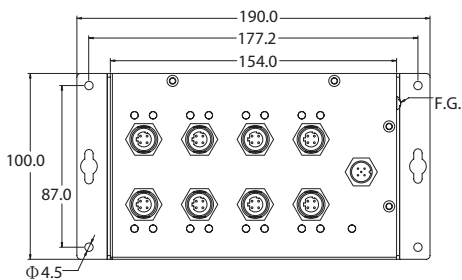

Front View

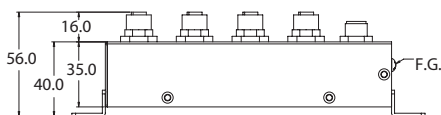

Bottom View

### Ordering Information

NSM-208-M12 CR	EN50155 8-port M12 Unmanaged Ethernet Switch (RoHS) Includes M12D-4P-IP68 x 8, A-CAP-M12M x 8, M12A-5P-IP68 and A-CAP-M12F x 1
NSM-208PSE-M12 CR	EN50155 8-port M12 Unmanaged PoE Ethernet Switch (RoHS) Includes M12D-4P-IP68 x 8, A-CAP-M12M x 8, M12A-5P-IP68 and A-CAP-M12F x 1

### Accessories

MDR-60-48	48 V/1.25 A, 60 W Power Supply with DIN-Rail Mounting
DIN-KA52F-48	48 V/0.52 A, 25 W Power Supply with DIN-Rail Mounting
KA52F-48	48 V/0.52 A, 25 W Power Supply

M12D-4P-IP68	A-CAP-M12M	M12A-5P-IP68	A-CAP-M12F
4PIO1K0000001	4PIO1K0000002	4PIO1K0000003	4PIO1K0000004
You need to choose high quality M12 cable, please refer to <a href="http://www.balluff.ca/Balluff">http://www.balluff.ca/Balluff</a>			