

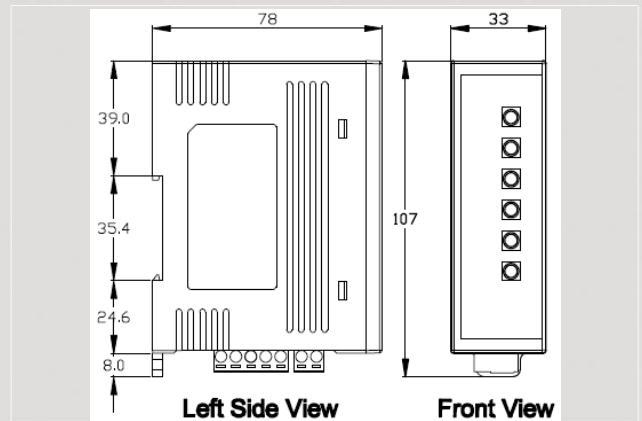

Universal IR Learning Remote Module



IR-210



Dimensions

IR-210 is a universal IR learning remote module which can learn IR remote commands of diverse electronic devices. The learning commands can be stored in the module or saved to a file. IR-210 supplies 6 IR output channels for individual and simultaneous control on multiple devices. The accompanied RS-232 and RS-485 interfaces with Modbus/RTU protocol provide more flexible expansion and control on the module. As a replacement of IR remote controls and a module that can be easily integrated with Modbus master devices (e.g. PAC, PLC, PC... etc.), IR-210 is well-suited for smart home and building automation.

Features

- 6 IR output channels for controlling multiple devices.
- 1 IR learning input.
- Supports learning IR carrier frequencies: 32.768、36、37.037、38、40 and 56 kHz.
- Can learn and store 176 IR commands.
- Supports RS-232 and RS-485 serial interface.
- Supports Modbus/RTU protocol.
- Assignable 256 Modbus Network IDs.
- Baud rate settings: 9600, 19200, 38400, 57600 and 115200 bps.
- Configurable NONE / ODD / EVEN parity and 1 or 2 stop bits.
- Provides transmitting / learning / power indication LEDs.
- Built-in Watchdog.
- RoHS Compliance.

Utility Features

- IR commands learning and testing.
- Save IR learning commands to files.
- Get / Set IR learning commands from / to IR-210.
- Reference to Modbus commands.
- Set / Reset basic settings of IR-210.

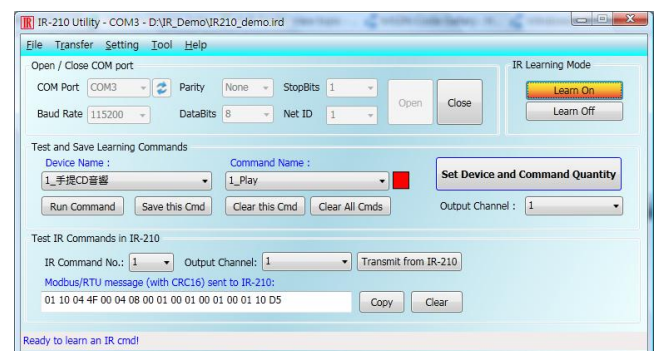

Wire Assignments

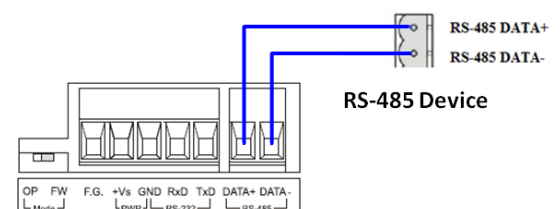
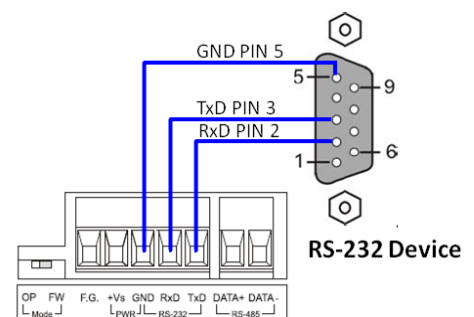



Hardware Specifications

Hardware	
CPU	32-bit MCU
IR Interface	
IR Output Channels	6 channels with 3.5 mm audio jack
IR Learning Input	1 channel. Supports 6 IR carrier frequencies: 32.768, 36, 37.037, 38, 40, 56 kHz.
UART Interface	
Connector	2-pin (RS-485) / 5-pin (RS-232, Power) screw terminal connector
COM1	RS-232 (TxD, RxD, GND)
COM2	RS-485 (DATA+, DATA-)
Baud Rate	9600, 19200, 38400, 57600, 115200 bps
Protocol	Modbus/RTU (slave)
LED	
Round LED	TR (IR Transmitting) / LN (IR Learning) / PWR (Power)
Power	
Power supply	+10 ~ +30 V _{DC}
Power Consumption	2.5 W Max
Dip Switch	FW (Firmware update mode) / OP (Firmware operation mode)
Mechanism	
Installation	DIN-Rail
Dimensions	33mm x 107mm x 78mm (W x H x D)
Environment	
Operating Temp.	-25 ~ +75°C
Storage Temp.	-30 ~ +80°C
Humidity	10 ~ 90% RH, non-condensing

Application

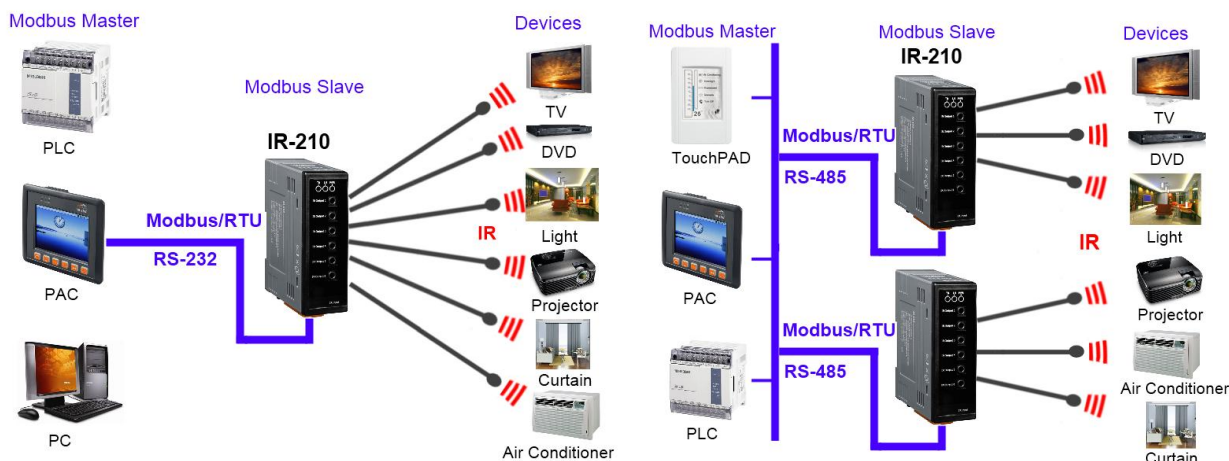

Ordering Information

IR-210 CR	Universal IR Learning Remote Module, including a CA-IR-SH2251 (RoHS)
------------------	--

Accessories

CA-IR-SH2251	Single-headed IR emitter (with adhesive pad, 2.5 m)
CA-IR-SH2252	Dual-headed IR emitter (with adhesive pad, 2.5 m)



Fieldworks Direct B.V. www.fieldworks.nl
 Veemarktkade 8 Tel. +31 (0) 73 624 1111
 NL-5222 AE 's-Hertogenbosch Fax +31 (0) 73 624 1112