

DI-8B35 Linearized 4-Wire RTD Input Modules

FEATURES

- Interfaces to 100Ω Platinum RTDs
- Linearizes RTD Signal
- High Level Voltage Outputs
- 1500Vrms Transformer Isolation
- ANSI/IEEE C37.90.1 Transient Protection
- Input Protected to 240VAC Continuous
- 120dB CMR
- 70dB NMR at 60Hz
- Low Drift with Ambient Temperature
- CSA, FM and CE Certifications Pending
- Mix and Match Module Types

DESCRIPTION

DI-8B modules are an optimal solution for monitoring real-world process signals and providing high level signals to a data acquisition system. Each DI-8B35 module isolates, filters, amplifies, and linearizes a single channel of temperature input from an RTD and provides an analog voltage output.

RTD excitation is provided from the module using a precision current source. Excitation current does not flow in the input signal leads, which allows RTD measurements to be made independent of lead resistance. The excitation currents are small (0.25mA) which minimizes self-heating of the RTD.

Signal filtering is accomplished with a three-pole filter optimized for time and frequency response which provides 70dB of normal-mode-rejection at 60Hz. One pole of this filter is on the field side of the isolation barrier for anti-aliasing, and the other two are on the system side.

A special input circuit on the DI-8B35 module provides protection against accidental connection of power-line voltages up to 240VAC. Clamp circuits on the I/O and power terminals protect against harmful transients.

The modules are designed for installation in Class I, Division 2 hazardous locations and have a high level of immunity to environmental noise.

SPECIFICATIONS

Typical at T_A = +25°C and +5V Power

		DI-8B35
Input Range Limits		-200°C to +850°C (100Ω Pt)
Input Resistance	Normal Power Off Overload	50MΩ 200kΩ 200kΩ
Input Protection	Continuous ¹ Transient	240VAC ANSI/IEEE C37.90.1
Sensor Excitation Current		0.25mA
Lead Resistance Effect		±0.005°C/Ω ²
CMV, Input to Output		1500Vrms max
Transient, Input to Output		ANSI/IEEE C37.90.1
CMR (50Hz or 60Hz)		120dB
NMR		70dB at 60Hz
Accuracy ³	DI-8B35-01 DI-8B35-02 DI-8B35-03 DI-8B35-04	Please Refer to Ordering Guide
Stability	Output Offset Gain	±20ppm/°C ±50ppm/°C
Noise	Output, 100kHz	200μVrms
Bandwidth, -3dB		3Hz
Response Time, 90% Span		150ms
Output Range		0 to +5V
Output Protection	Transient	Continuous Short to Ground ANSI/IEEE C37.90.1
Power Supply Voltage		+5VDC ±5%
Power Supply Current		25mA
Power Supply Sensitivity		±25ppm/%
Mechanical Dimensions		1.11" × 1.65" × 0.40" (28.1mm × 41.9mm × 10.2mm)
Environmental	Operating Temperature Storage Temperature Relative Humidity	-40°C to +85°C -40°C to +85°C 0 to 95% Noncondensing
RTD Standards	Type Alpha Coefficient	100Ω Pt 0.00385

¹240VAC between + and - /+EXC/-EXC terminals. 120VAC between - and +EXC/-EXC terminals and between +EXC and -EXC terminals.

²Ω refers to the resistance in one lead.

³Includes conformity, hysteresis and repeatability.

DI-8B35 4-Wire RTD Input Module

Block Diagram

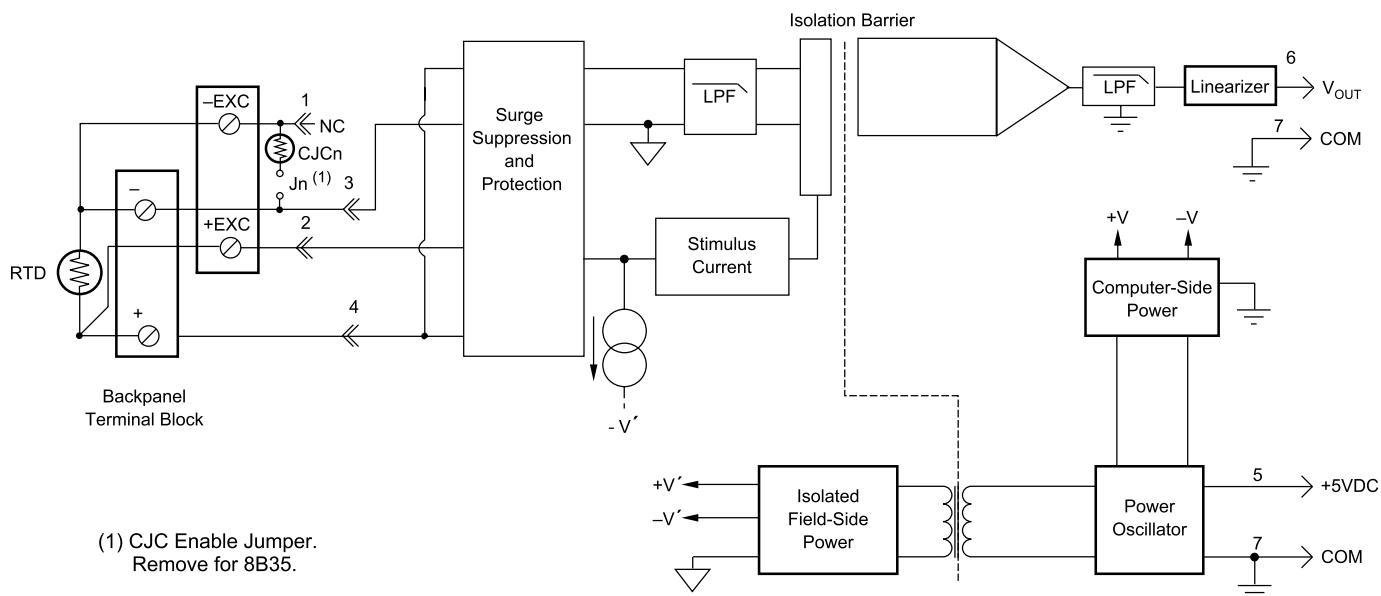

Ordering Information

Model Number	Input Range	Accuracy*
DI-8B35-01	-100°C to +100°C (-148°F to +212°F)	±0.20°C
DI-8B35-02	0°C to +100°C (+32°F to +212°F)	±0.10°C
DI-8B35-03	0°C to +200°C (+32°F to +392°F)	±0.20°C
DI-8B35-04	0°C to +600°C (+32°F to +1112°F)	±0.45°C

*Includes conformity, hysteresis, and repeatability.



241 Springside Drive
Akron, Ohio 44333
330-668-1444

Data Acquisition Product Links

(click on text to jump to page)

[Data Acquisition](#) | [Data Logger](#) | [Chart Recorder](#) | [Thermocouple](#) | [Oscilloscope](#)