

**Stand-alone Data Logger  
Option Allows Data to be  
Saved to Removable SD  
Memory**

**Accepts 16 Fully Isolated  
DI-8B Plug-In Amplifiers**

**Sample Rates from  
0.0017Hz up to 14,400Hz**



DI-718Bx with the top hatch removed, eight DI-8B modules installed, and eight DI-8B modules sitting atop the instrument.

DATAQ Instruments' DI-718Bx Series Data Acquisition/Data Logger System is designed for general purpose and stand-alone data logging applications that require signal conditioning. DI-718Bx instruments may be purchased with or without stand-alone capability. Instruments without this option must remain tethered to a PC's Ethernet port (can be via a network) during data acquisition and use the PC's own program and memory to store acquired data. Instruments with the stand-alone data logging option feature a built-in socket that accepts standard Secure Digital (SD) memories to which acquired data may be stored. SD memories are the same commonly available mass storage devices used with digital cameras and MP3 players.

Compact and low cost DI-8B amplifiers may be plugged directly into the DI-718Bx and are the world's smallest fully functional isolated analog signal conditioners. Each DI-8B module protects, filters, amplifies, and isolates an input signal and provides an advanced signal conditioning solution for nearly any industrial measurement. The compact nature of both the DI-718Bx and DI-8B modules combine to form the smallest data logger/acquisition instrument in its class. All DI-718Bx instruments are supplied with four removable 16-position screw terminal connectors to provide access to the built-in DI-8B module backplane. Instruments are housed in a small (9"L × 7.29"W × 1.52"H; 22.9L × 18.5W × 3.86H cm) enclosure consisting of an aluminum base, all-steel wraparound, aluminum end plates and removable top hatch.

## Features

### Make Industrial Measurements Through DI-8B Plug-in Signal Conditioning Modules

Each channel on the DI-718Bx accommodates one DI-8B module providing a single channel of isolated input protection, amplification, and filtering. DI-8B modules are plugged into a socketed backplane and are secured with a mounting screw. Each channel has 4 corresponding screw terminals for signal connections: channel+, channel-, excitation+, and excitation-. These terminals satisfy all transducer inputs and provide sensor excitation if necessary. Access to the DI-8B modules is through a removable top hatch.

### Stand-alone Data Logger Operation

Use an SD Card to record and store data—up to 2GB. A FIFO memory configuration allows the DI-718Bx to record continuously using a circular buffer or record-until-full approach. A push button allows manual start/stop control over the recording process. A multi color LED shows instrument status (Record, Standby, Busy, Error).

### Wide Range of Throughput Rates

Supports sample throughput rates from 0.0034 Hz up to 4800 Hz when acquiring data with a PC or from 0.0017 Hz (6.1 samples per hour) to up to 14400 Hz when recording to removable SD memory (stand-alone data loggers).

### High Resolution

14-bit resolution analog to digital conversion provides a responsive instrument capable of registering changes as small as one part in 8,192 ( $\pm 0.012\%$  of the full scale measurement range).

### Easy to Connect and Use

Installs in seconds. Simply connect to an accessible Ethernet port (an extra-cost USB to Ethernet converter is available). Connect power, then connect your signals to the provided screw terminal blocks (16 ports each). Stand-alone data loggers just require an SD card and power.

### File Protection

When powered down unexpectedly, the DI-718Bx Stand-alone model retains all acquired data on its memory card.

### Includes Software

Be up and running minutes out of the box with WINDAQ software. Use WINDAQ/Lite Acquisition software (free) to record at rates up to 1000 Hz throughput. WINDAQ/High Speed option allows you to record data as fast as the instrument will allow. Use WINDAQ Playback software (free) to review, measure, compare, and analyze waveform data during or after a recording session.

Configuration Software is included for all stand-alone data loggers allowing a complete data acquisition configuration to be designed and downloaded to the DI-718Bx from any local or remote PC. Upload software is also provided to allow you to read data stored to SD memory over the DI-718Bx's Ethernet interface.

## DI-718Bx Front Panel and Top Hatch

### Removable Top Hatch

Remove the top hatch to install your DI-8B modules.

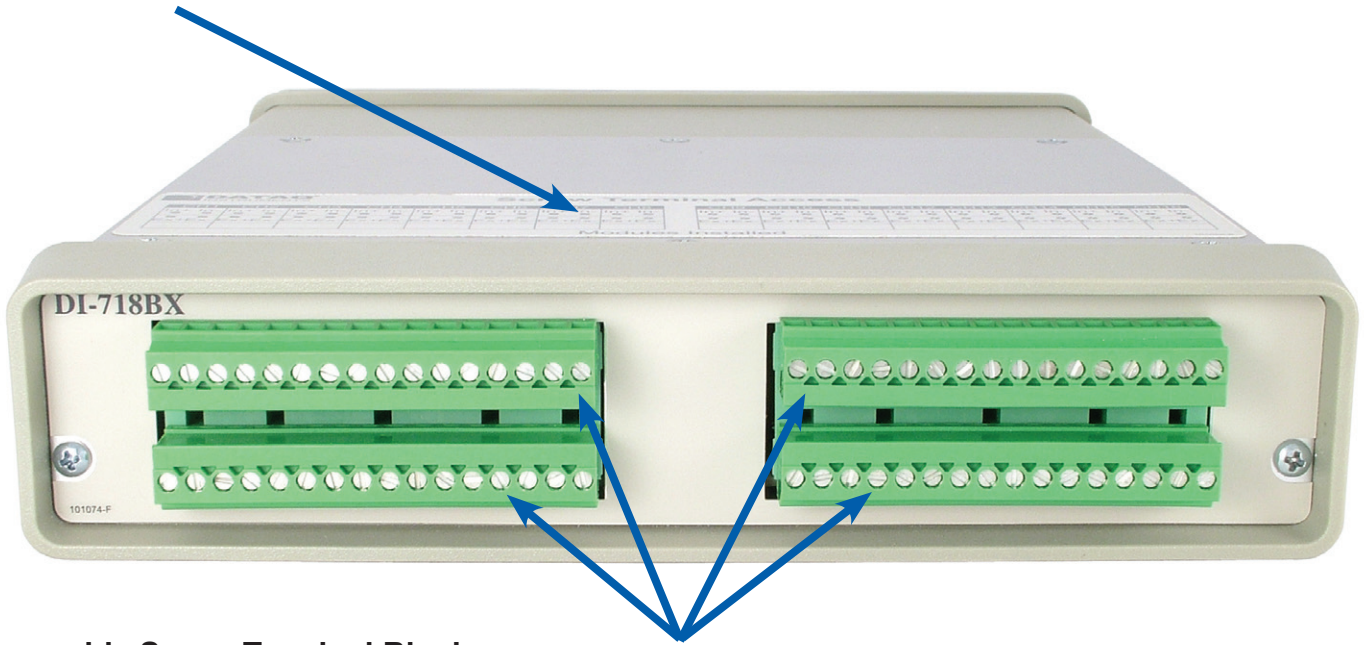

### Removable Screw Terminal Blocks

Connect signal leads to these four removable screw terminal blocks. Channel+, Channel-, Excitation+, and Excitation- for each channel.

## DI-718Bx Rear Panel

### “Mode” LED

Tri-color LED indicates instrument status: Standby, Recording, Error.

### Digital I/O and Monitor Out

Connect to 8 digital I/O ports using CABL-7 and the DI-705.

### Power Jack

May be powered by the provided AC adaptor, or from any 9-36 VDC source. Consumes 2 watts.

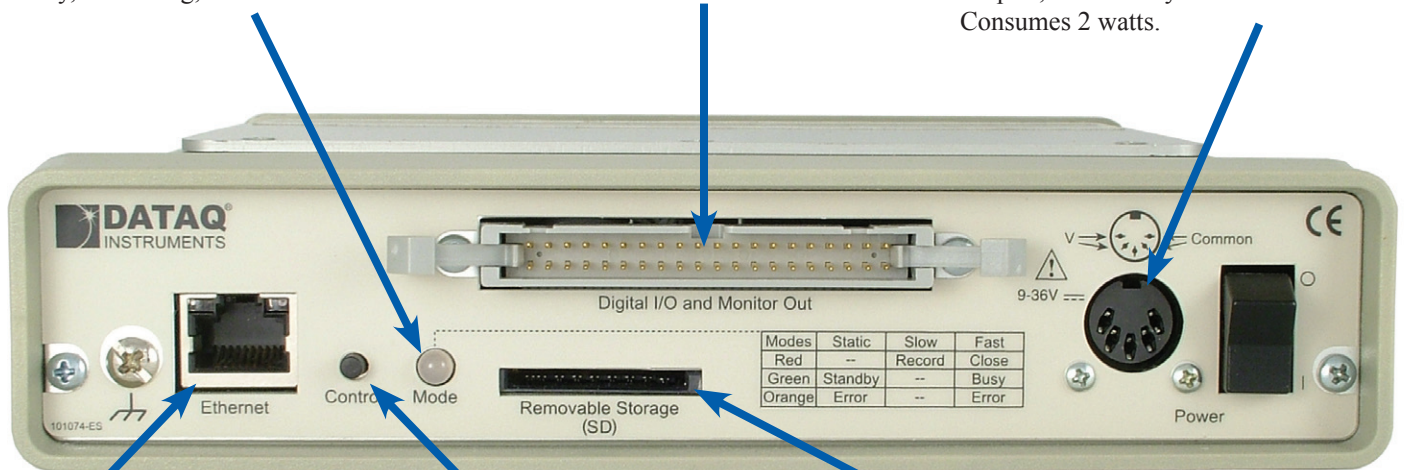

### Interface

Connect with a CAT5 cable to any spot on your network. An optional external Ethernet to USB converter is available (part number 101014-EA).

### “Control” Push-button

Allows manual start/stop local control over the recording process and instrument configuration.

### Removable Storage Slot

Accommodates standard and readily available multi-media memory cards for mass storage. These are the same memories used by consumer electronic devices like MP3 players and digital cameras. Accepts memory sizes from 16 MB to 2 GB.

# Stand-alone Data Transport Methods



Physically Transport Memory Card  
Remove SD and place in Reader

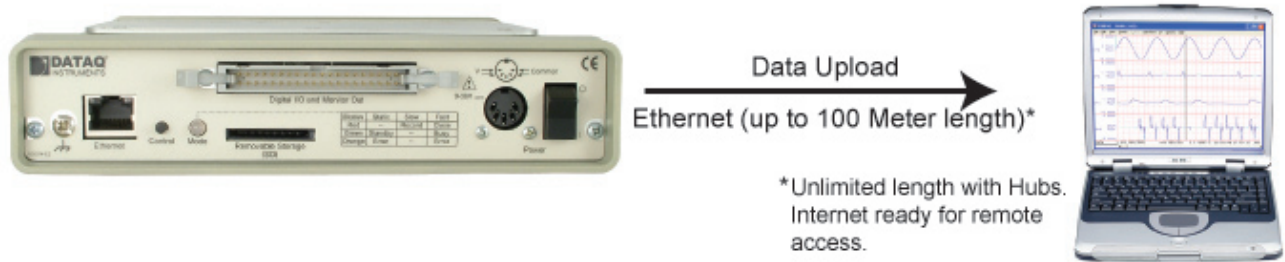

\*Unlimited length with Hubs.  
Internet ready for remote access.

# Block Diagram

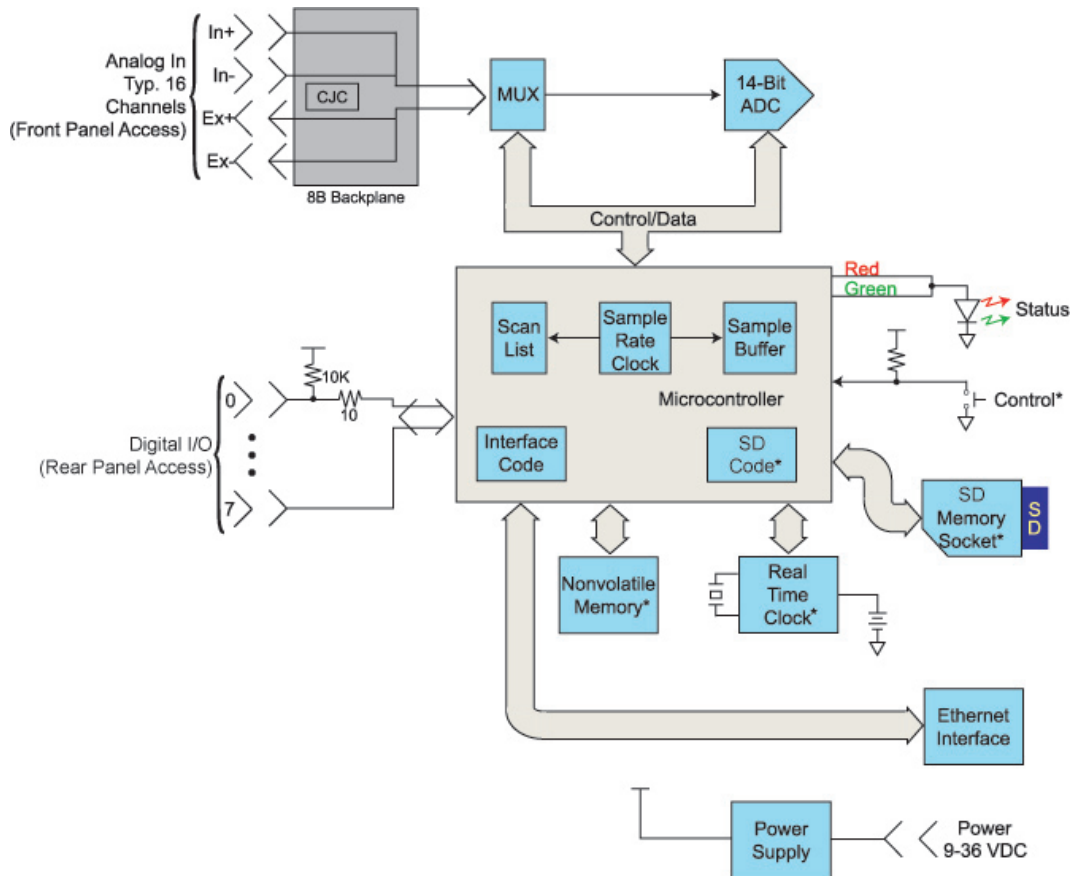

\*Stand-alone models only

## DI-718Bx Deployment Methods

### Six Deployment Methods

Ethernet Models add a new dimension to Data Acquisition applications allowing data access over a LAN to a PC on the other side of your facility or over the internet to a PC on the other side of the world. For more information view our application note on the internet at: [http://www.dataq.com/applicat/articles/data\\_logger\\_ethernet02.htm](http://www.dataq.com/applicat/articles/data_logger_ethernet02.htm).

#### Deployment #1 - One PC directly connected to one DI-718Bx with a crossover cable.



#### Deployment #2 - One or more PCs, one or more DI-718Bxs on a Dedicated Network.

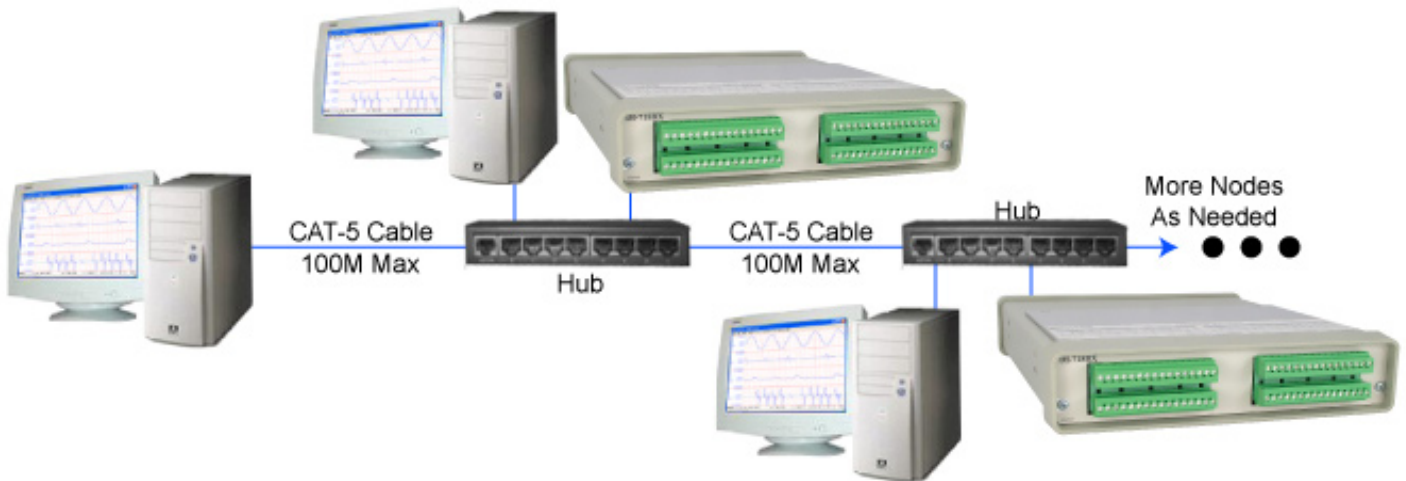

#### Deployment #3 - One or more PCs, one or more DI-718Bxs on a LAN.

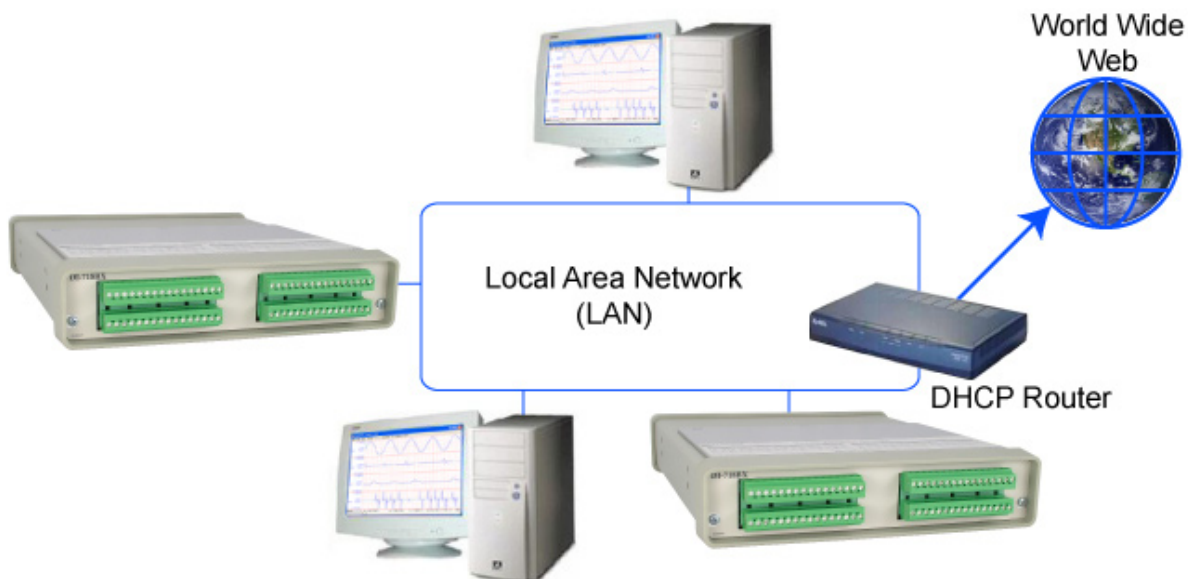

## DI-718Bx Deployment Methods

Deployment #4 - One or more PCs, one or more DI-718Bxs on a Wireless Network.

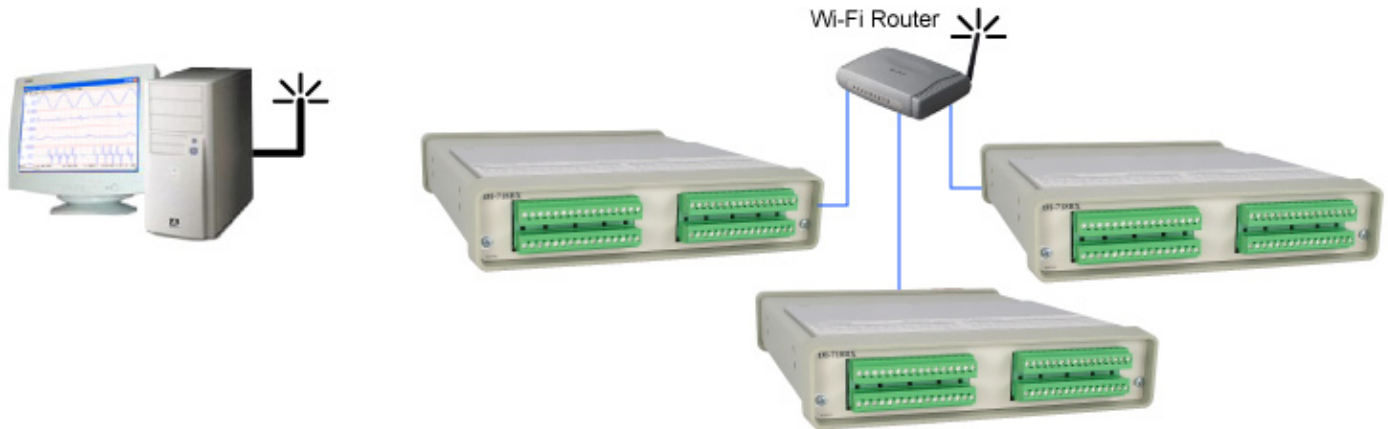

Deployment #5 - One or more PCs, one or more DI-718Bxs remotely to different LAN subnets.

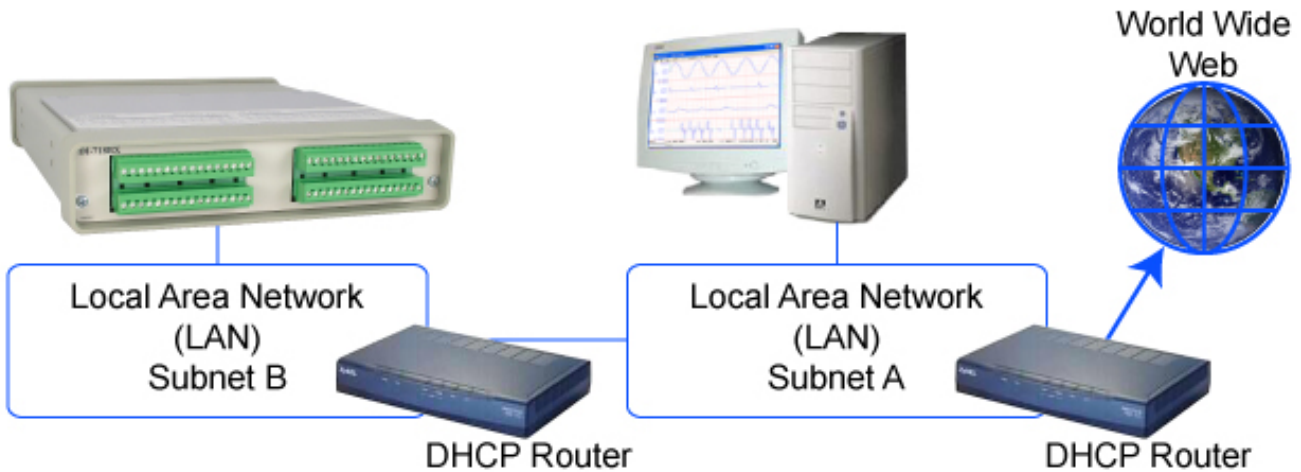

Deployment #6 - One or more PCs, one or more DI-718Bxs remotely over the Internet.

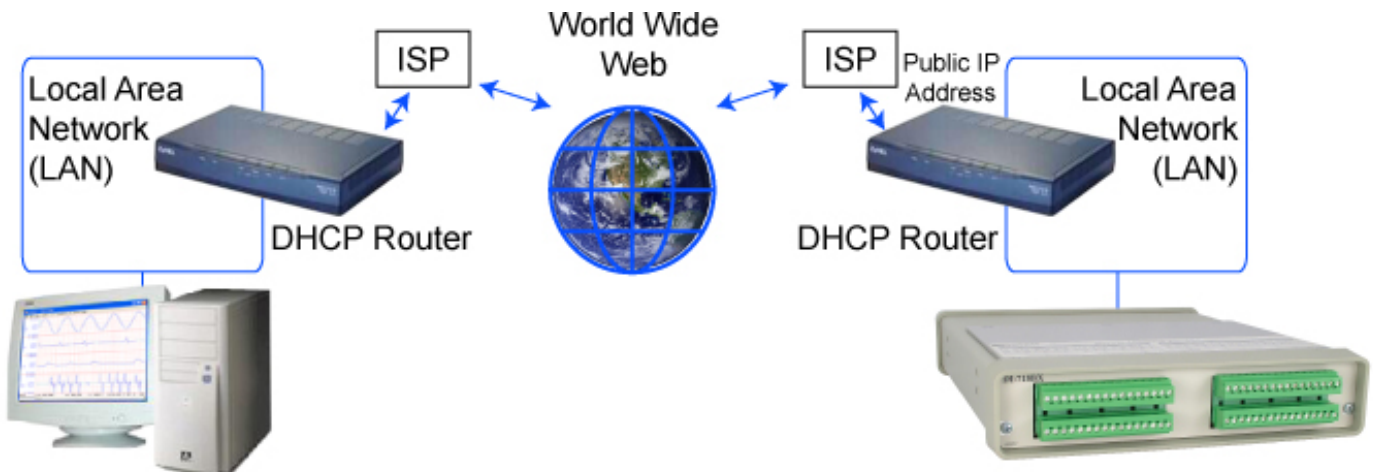

View the Ethernet Resource Page for application notes and demos on Ethernet Data Acquisition with DI-71X products. Go to <http://www.dataq.com/applicat/ethernet.htm> for more information.

### What you can measure

Both low and high-level signal acquisition for industrial monitoring and recording in maintenance and troubleshooting, as well as quality control applications to measure:

- Programmable logic controller (PLC) parameters.
- Voltage measurements in the range of millivolts to 10 volts.
- 4-20 mA process current loops.
- Transducer outputs at either millivolt or high levels for:
  - Force;
  - Temperature;
  - Pressure/vacuum;
  - Torque;
  - RPM/Speed;
  - Load;
  - Strain;
  - Distance;
  - Many more.

### Where you can measure

Design qualification and maintenance and troubleshooting applications where various mechanical and/or electrical parameters as described above are to be measured. These include such applications as:

- In-vehicle automotive testing.
- Remote wireless radio monitoring for signal strength, power supply voltages, etc.
- Agricultural equipment testing.
- Electromechanical timing and amplitude measurements on presses and mills (paper, steel, tube).

### Tethered to a PC...

Use a PC-tethered DI-718Bx anywhere it can remain connected to a laptop or desktop PC for long or short-term measurements. The Ethernet interface allows the PC to be used locally or remotely (up to 100 meters without hubs). Because PC-tethered versions must communicate constantly with the host without latencies, dedicated networks are recommended for PC-tethered versions.

### ...or Stand-alone

DI-718Bx Stand-alone models can be used in all the same applications as PC-tethered versions, except data may also be stored locally to removable SD memory without a PC. Remote uploading of stored SD memory data can be achieved using the Ethernet interface from anywhere on a LAN, WAN, or the Internet. Stand-alone features are designed for those who:

- Cannot locate a PC near the instrument for fear of theft or damage.
- Want easy and efficient access to remotely recorded information over their Ethernet LAN without leaving the comfort and security of their office.
- Want to record 24/7/365 as an aid to either process maintenance and troubleshooting, quality control, or design qualification without the added complexity and instability of a dedicated PC running Windows.
- Want remote, Ethernet- accessible data without the time and cost burden required to install a dedicated network.

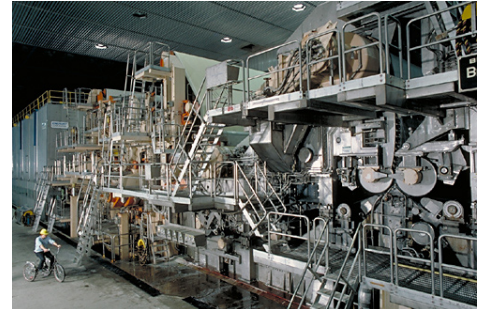
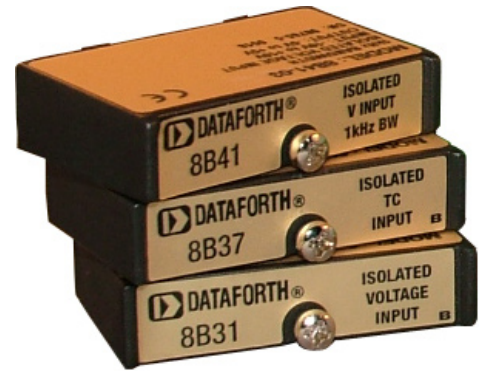

# DI-8B Signal Conditioning Module Applications

## AC or DC Current Shunt

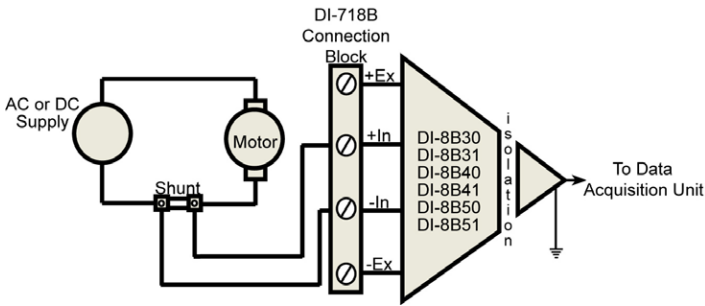

## Frequency

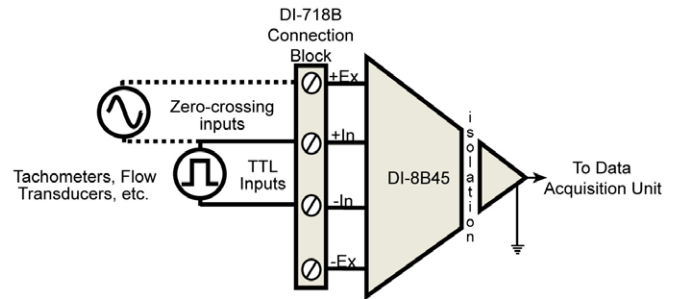

## Process Current

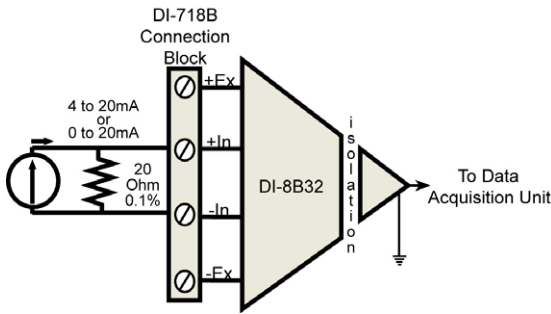

## Full-Bridge Strain Gage

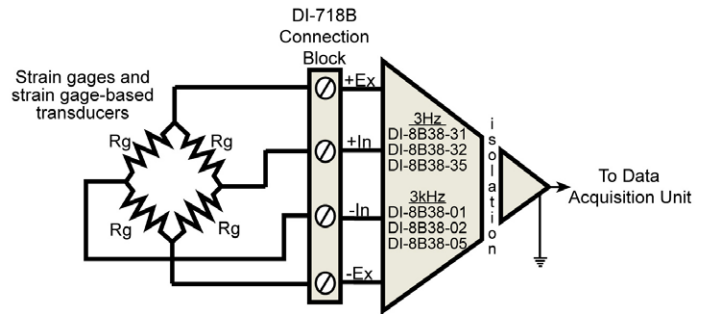

## Floating Grounded TC

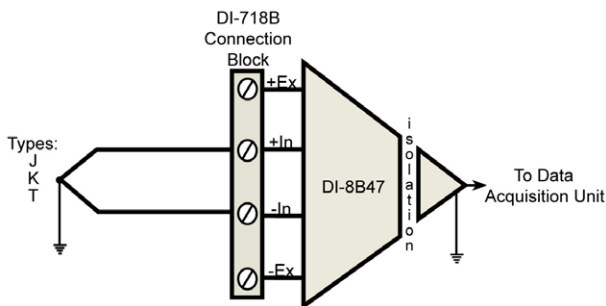

## RTD

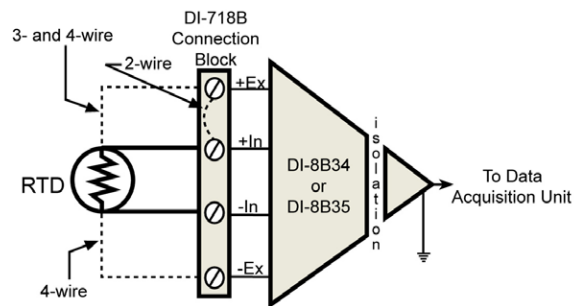

# DI-8B Signal Conditioning Module Selection Guide

Each DI-8B module is a single channel, isolated analog input designed for a specific measurement. The modules filter, isolate, amplify, and convert input signals to a high-level analog signal suitable for A/D conversion. Over 50 modules address the full spectrum of industrial measurements.

## Key Features

- Convenient, flexible, mix-and-match approach.
- Full isolation reduces noise and protects you and your equipment from large, common mode voltages.
- Small size 1.105" × 1.65" × 0.40".

## Common Specifications

- 1000V Input-to-Output Isolation.
- 500V Channel-to-Channel Isolation.
- 240 VAC input protection.
- 160db common mode rejection.

### Voltage Input Modules (3Hz BW)

MODEL NO.	Input Range
DI-8B30-01	±10mV
DI-8B30-02	±50mV
DI-8B30-03	±100mV
DI-8B31-01	±1V
DI-8B31-02	±5V
DI-8B31-03	±10V
DI-8B31-07	±20V
DI-8B31-09	±40V
DI-8B31-12	±60V

### Current Input Modules (3Hz BW)

MODEL NO.	Input Range
DI-8B32-01	4 to 20mA
DI-8B32-02	0 to 20mA

### Isolated True RMS Input Modules

MODEL NO.	Input Range
DI-8B33-01	0mV to 100mV
DI-8B33-02	0V to 1V
DI-8B33-03	0V to 10V
DI-8B33-04	0V to 150V
DI-8B33-05	0V to 300V

### Linearized 2- or 3-wire RTD Modules (3Hz BW)

MODEL NO.	Type	Input Range
DI-8B34-01	100Ω Pt	-100°C to +100°C (-148°F to +212°F)
DI-8B34-02	100Ω Pt	0°C to +100°C (+32°F to +212°F)
DI-8B34-03	100Ω Pt	0°C to +200°C (+32°F to +392°F)
DI-8B34-04	100Ω Pt	0°C to +600°C (+32°F to +1112°F)

### Linearized 4-wire RTD Modules (1kHz BW)

MODEL NO.	Type	Input Range
DI-8B35-01	100Ω Pt	-100°C to +100°C (-148°F to +212°F)
DI-8B35-02	100Ω Pt	0°C to +100°C (+32°F to +212°F)
DI-8B35-03	100Ω Pt	0°C to +200°C (+32°F to +392°F)
DI-8B35-04	100Ω Pt	0°C to +600°C (+32°F to +1112°F)

### Potentiometer Input Modules (3Hz BW)

MODEL NO.	Input Range
DI-8B36-01	0 to 100Ω
DI-8B36-02	0 to 500Ω
DI-8B36-03	0 to 1kΩ
DI-8B36-04	0 to 10kΩ

### Strain Gage Input Modules

MODEL NO.	Type	Bandwidth	Input Range
DI-8B38-01	Full	8kHz	±10mV, 3mV/V 100 to 10k
DI-8B38-02	Full	8kHz	±30mV, 3mV/V 300 to 10k
DI-8B38-05	Full	8kHz	±20mV, 2mV/V 300 to 10k
DI-8B38-31	Full	3Hz	±10mV, 3mV/V 100 to 10k
DI-8B38-32	Full	3Hz	±30mV, 3mV/V 300 to 10k
DI-8B38-35	Full	3Hz	±20mV, 2mV/V 300 to 10k

### Voltage Input Modules (1kHz BW)

MODEL NO.	Input Range
DI-8B40-01	±10mV
DI-8B40-02	±50mV
DI-8B40-03	±100mV
DI-8B41-01	±1V
DI-8B41-02	±5V
DI-8B41-03	±10V
DI-8B41-07	±20V
DI-8B41-09	±40V
DI-8B41-12	±60V

### Current Input Modules (3Hz BW)

MODEL NO.	Input Range
DI-8B42-01	4 to 20mA
DI-8B42-02	4 to 20mA

### Frequency Input Modules (3Hz BW)

MODEL NO.	Input Range
DI-8B45-01	0 to 500Hz
DI-8B45-02	0 to 1kHz
DI-8B45-03	0 to 3kHz
DI-8B45-04	0 to 5kHz
DI-8B45-05	0 to 10kHz
DI-8B45-06	0 to 25kHz
DI-8B45-07	0 to 50kHz
DI-8B45-08	0 to 100kHz

### Linearized Thermocouple Input Modules (3Hz BW)

MODEL NO.	Type	Input Range
DI-8B47J-01	J	0°C to +760°C (+32°F to +1400°F)
DI-8B47J-02	J	-100°C to +300°C (-148°F to +572°F)
DI-8B47J-03	J	0°C to +500°C (+32°F to +932°F)
DI-8B47J-12	J	-100°C to +760°C (-148°F to +1400°F)
DI-8B47K-04	K	0°C to +1000°C (+32°F to +1832°F)
DI-8B47K-05	K	0°C to +500°C (+32°F to +932°F)
DI-8B47K-13	K	-100°C to +1350°C (-148°F to +2462°F)
DI-8B47K-14	K	0°C to +1200°C (+32°F to +2192°F)
DI-8B47T-06	T	-100°C to +400°C (-148°F to +752°F)
DI-8B47T-07	T	0°C to +200°C (+32°F to +392°F)

### Voltage Input Modules (20kHz BW)

MODEL NO.	Input Range
DI-8B50-01	±20mV
DI-8B50-02	±50mV
DI-8B50-03	±100mV
DI-8B51-01	±1V
DI-8B51-02	±5V
DI-8B51-03	±10V
DI-8B51-07	±20V
DI-8B51-09	±40V
DI-8B51-12	±60V



# DI-718Bx Specifications

## Analog Inputs

<b>Number of Channels:</b>	16 configured for signal conditioned inputs
<b>Channel Configuration:</b>	Defined by DI-8B Module
<b>Measurement Range:</b>	Defined by DI-8B Module
<b>Accuracy:</b>	±.05%FSR ±50µV + 8B module + CJC error (test conditions: 1 channel; 100 S/s; averaging mode)
<b>Resolution:</b>	±1 part in 8,192
<b>Input Impedance:</b>	Defined by DI-8B Module
<b>Input offset voltage:</b>	Defined by DI-8B Module
<b>Channel-to-channel crosstalk rejection:</b>	-75db @ 100Ω unbalance
<b>Offset temperature coefficient:</b>	0.25µV/°C
<b>Digital filtering:</b>	Standard: Conditional over-sampling Stand-alone: None
<b>CJC Error:</b>	±1.5°C plus 8B Module
<b>Gain:</b>	1, 2, 4, 8 (software selectable per channel)

## Isolation (via DI-8B Modules)

<b>Input-to-Output:</b>	1000VDC/Peak AC
<b>Channel-to-Channel:</b>	500VDC/Peak AC

## A/D Characteristics

<b>Type:</b>	Successive approximation
<b>Resolution:</b>	14-bit
<b>Monotonicity:</b>	±2 LSB
<b>Conversion Time:</b>	69.4µs

## Scanning Characteristics

<b>Max. throughput sample rate:</b>	Standard: 4,800 Hz Stand-alone: 14,400 Hz (assumes SD memory latencies of 80 milliseconds or less)
<b>Min. throughput sample rate:</b>	Standard: 0.0034 Hz Stand-alone: 0.0017 Hz
<b>Max. scan list size:</b>	18 entries
<b>Sample buffer size:</b>	2kb

## Controls (Stand-alone models)

<b>Single push-button:</b>	Provides manual control over Record and Standby
----------------------------	---

## Calibration

<b>Calibration cycle:</b>	One year
---------------------------	----------

## Digital I/O

<b>Bits:</b>	8 bi-directional ports
<b>Input voltage levels:</b>	Min. required "1" 2V; Max allowed "0" 0.8V

## Ethernet Interface (optional Ethernet to USB converter available)

<b>Type:</b>	10/100Base-T
<b>Connector:</b>	RJ-45
<b>Protocol:</b>	TCP/IP
<b>Server Type:</b>	DHCP or Fixed IP

## Removable Memory (Stand-alone models)

<b>Type:</b>	SD (Recommended: Lexar Professional 133X)
<b>Capacity:</b>	16MB to 2GB

## Real Time Clock (Stand-alone models)

<b>Type:</b>	Date, hour, minute, second
<b>Resolution:</b>	1 second
<b>Accuracy:</b>	20 ppm

## Transfer Rate to PC

<b>Real Time:</b>	up to 4,800 samples per second
<b>From Memory Card:</b>	up to 3,000 samples per second

## General

<b>Panel indicators:</b>	Mode LED
<b>Panel Controls:</b>	Control push button (Stand-alone models)
<b>Panel Slots:</b>	Accepts MMC/SD-type flash memory
<b>Input connectors:</b>	Four, removable sixteen position terminal blocks
<b>Operating Environment:</b>	0°C to 70°C
<b>Enclosure:</b>	Aluminum base with steel wrap-around. Removable aluminum top hatch for 8B module installation.
<b>Dimensions:</b>	7.29W × 9L × 1.52H in. 18.52W × 22.86L × 3.86H cm.
<b>Weight:</b>	2 lbs. 10 oz. (1.19 kg) + DI-8B modules
<b>Power Requirements:</b>	9 to 36 VDC, 2.5 watts + 8B modules
<b>Indicators</b>	
<b>Stand-alone models:</b>	Three-color LED indicating Record, Standby, and Error conditions
<b>Standard models:</b>	Power LED

## Ordering Guide

Description	Order No.	Description	Order No.
<b>DI-718Bx Ethernet Instrument</b> Low cost, portable, Ethernet data logger featuring throughput rates up to 4800 Hz, and sixteen DI-8B Module inputs.	DI-718Bx	<b>DI-718Bx-S Ethernet Stand-alone Instrument</b> Low cost, portable, Ethernet data logger featuring throughput rates up to 14400 Hz, sixteen DI-8B Module inputs and stand-alone capability.	DI-718Bx-S
<b>WINDAQ/HS-718B</b> High-Speed WINDAQ Acquisition software for DI-718B Instruments.	WINDAQ/HS-718B	<b>SD Card Reader</b> Reads Secure Digital (SD) and MultiMedia Card (MMC) Memories. For use with Stand-alone models.	101014-CR
<b>SD Card</b> Lexar Professional 133X 1 Gigabyte Secure Digital Flash Memory.	101014-1G	<b>USB to Ethernet Converter</b> Converter that allows you to connect your DI-718Bx to a USB port. Manufacturer varies. Adds an external network card to your PC through the USB port.	101014-EA



DATAQ Instruments, Inc.  
241 Springside Drive  
Akron, Ohio 44333  
Phone: 330-668-1444  
Fax: 330-666-5434

## Data Acquisition Product Links

(click on text to jump to page)

[Data Acquisition](#) | [Data Logger](#) | [Chart Recorder](#) | [Thermocouple](#) | [Oscilloscope](#)

DATAQ, the DATAQ logo and WinDaq are registered trademarks of DATAQ Instruments, Inc. All rights reserved. Copyright © 2010 DATAQ Instruments, Inc. The information on this data sheet is subject to change without notice. DI-8B modules are designed and manufactured by Dataforth Corporation