

Ethernet-to-GPIB Instrument Interface

DESCRIPTION

ICS's 8055 is a Ethernet-to-GPIB Instrument Interface that adds a LAN interface to a GPIB instrument. The 8055 connects the GPIB instrument to any TCP/IP network and provides a VXI-11 service which is easily accessed by all popular test application languages. The 8055 maps VXI-11.3 and RPC requests into GPIB commands to control the GPIB instrument. The 8055-instrument combination becomes a VXI-11.3 compatible instrument. The 8055 makes it easy to run the instrument anywhere without a GPIB Controller, to include your instrument in an LXI or Ethernet based test system or to run remote tests anywhere in the world over the Internet.

VXI-11 and the 8055-Instrument

The VXI-11 Standard was created along with the VISA library specification as a way to control instruments over a TCP/IP network. The VXI-11 Specification has three sub-standards. The VXI-11.3 sub-specification describes how to control and communicate with IEEE-488.2 LAN instruments like the 8055-GPIB Instrument combination.

Because the 8055-instrument combination is VXI-11 compliant it can be controlled by a very wide range of applications and programming languages. A VXI-11.3 instrument like the 8055 can operate in Windows systems with VISA or SIDL libraries and in any UNIX/LINUX or similar operating systems with RPC calls. The VXI-11 specification provides an RPCL (Remote Procedure Call Library) that can be used by virtually any UNIX/LINUX or similar operating system to control your instrument. Refer to ICS Application Bulletin AB80-11 for more information on how this is done.

The 8055 will also operate in an LXI system but may need IVI drivers for LXI compatibility.

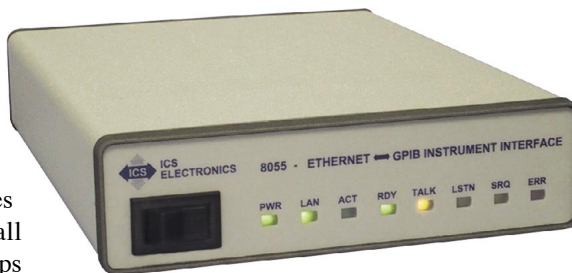

8055 Ethernet-to-GPIB Controller

Windows Programming

In most cases existing programs that controlled the instrument through a GPIB controller can be easily adapted to control the instrument through the 8055. If the application program was written with VISA calls, it is just a matter of changing the VISA Resource string to select a TCPIP device. NI's Measurement and Automation Explorer treats the 8055 and your instrument as any other VXI-11.3 instrument. Agilent's Connection Manager also sees the 8055-instrument combination as a VXI-11.3 instrument. MATLAB and other speciality applications that use VISA can also control the 8055-instrument combination.

If the application program was making direct GPIB calls, it will need to be changed to make VISA calls. Visual Basic, VB.NET or C/C++/C# programs can be written to control the 8055-instrument combination with SIDL or VISA calls.

If the companion GPIB instrument has an IVI Driver, it can be easily integrated into a test program written for LXI instruments.

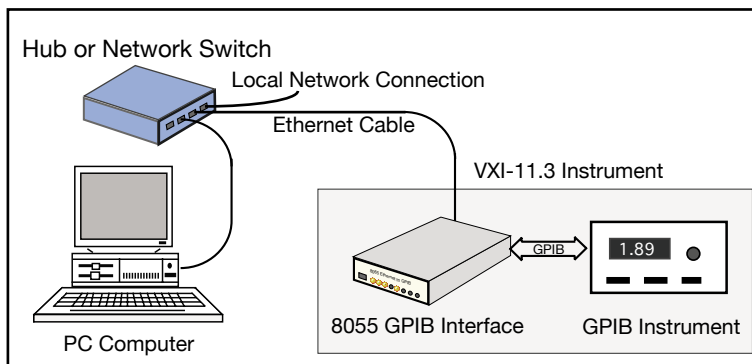

Converts a GPIB Instrument into a VXI-11.3 Instrument

- Adds a versatile LAN interface to a GPIB Instrument *Adapts GPIB instruments for VXI-11 or LXI Test Systems.*
- Runs from any VXI-11 compliant VISA or SIDL library. *Supports VEE, LabVIEW, C, and Visual Basic programs on Windows or HP-UX OS.*
- Uses RPC calls over a TCP/IP network. *Controllable by UNIX, LINUX, SunOS, Apple OS X and similar operating systems.*
- Does not require special drivers for each operating system. *Eliminates driver problems.*
- Reuse existing instruments in Ethernet test systems. *Saves instrument replacement-costs.*
- Configurable with a web browser, with a windows configuration program or RPC commands. *Easy network configuration from any computer.*
- Includes ICS's VXI-11 keyboard program. *The easy way to test IO configurations before writing a test program.*

CE Approved

RoHS



7034 Commerce Circle
Pleasanton, CA 94588
Phone: 925.416.1000
Fax: 925.416.0105
Web: www.icselect.com

UNIX/LINUX Programming

If you use Linux or any variation of Unix like SunOS, IBM-AIX, HP-UX, or Apple's OS X, you can communicate with your instrument through the 8055's network service with RPC calls. Special Drivers are not required. These operating systems include an RPCgen utility that converts the VXI-11 Specification's RPC library into a header file that can be called with a C language test program. There is nothing to become obsolete nor is a new driver ever required when the test computer or the operating system is updated or when the test program is ported to another UNIX/LINUX type system.

Connections

The 8055 can be used as an external box or embedded inside the instrument. In either case, users can connect to the instrument over the GPIB bus or through the 8055's Ethernet port. When connected to an active network, the 8055 checks the GPIB bus and stays in an idle state if another controller is connected to the GPIB bus. The 8055 only becomes the active controller if the GPIB bus is free.

8055's Operation

The 8055 transparently passes all device commands and IEEE-488.2 Common Commands onto the instrument and returns all instrument responses to the client application. The 8055 also does such familiar GPIB tasks as sending Selected Device Clears and Device Triggers to the instrument, pulse the IFC line, set Local or set Remote modes and perform Serial Polls.

SRQs can be passed back to the test application if the application has created a Reverse Interrupt Channel. When the 8055 detects an SRQ, the *inst* personality with a Reverse Interrupt Channel is serial polled and a *device_int_srq* RPC sent to the test application.

Network Setup & Installation

ICS's 8055 is very easy to install. Plug the 8055 into a network access point adjacent to your computer as shown in Figure 1 or use an Ethernet crossover cable to connect the 8055 directly to a PC's network port as shown in Figure 3. Use a web browser or run ICS's

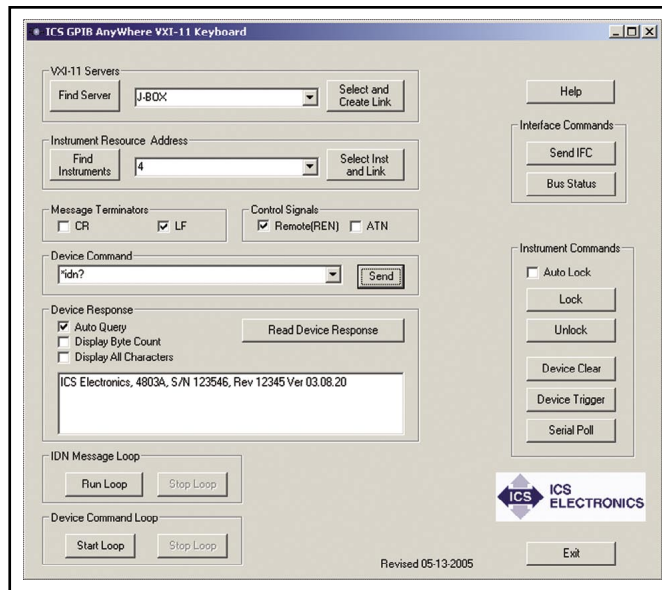

Figure 2 VXI-11 Keyboard Controller Panel

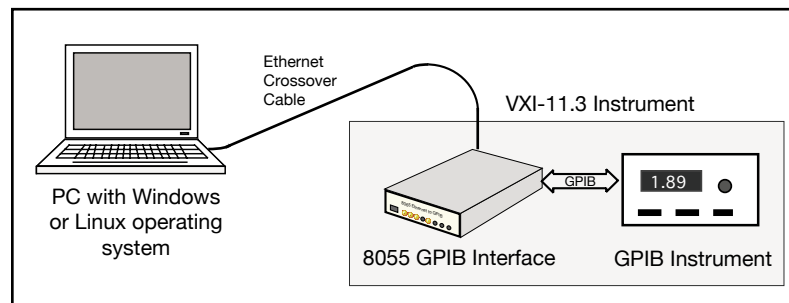

Figure 3 Laptop controlling the 8055-Instrument Combination

Configuration Utility to configure the unit for your network. Both let you set the 8055 to a static IP address or enable the 8055 to accept an DHCP address setting if the network has a server that can assign network addresses. Set the remaining network parameters, save the settings and the 8055 is ready to be connected to the instrument and to the network. A rear panel LAN Reset button is provided to reset the 8055's network settings to the factory default settings in case the 8055's configuration needs to be reset.

GPIB Setup

The 8055 can be configured to work with virtually any IEEE-488.2/GPIB Instrument. Use ICS's Windows Configuration program to assign the instrument's GPIB addresses to *inst* personalities starting with *inst0*. A typical instrument with a single primary address would use *inst0*. An instrument with dual primary addresses would use *inst0* and *inst1*. A multi-channel instrument with 8 secondary addresses would use *inst0* through *inst7*. Once configured, the 8055 will track any changes to the instrument's base GPIB address.

Keyboard Controller

The 8055 includes ICS's VXI-11 Keyboard program for Windows which provides interactive control of VXI-11 instruments from the computer keyboard without having to write a program. The VXI-11 Keyboard program is the ideal utility program for testing the 8055-instrument combination or for trying out device commands before using them in a program.

With the VXI-11 Keyboard program you can find and link to the 8055-instrument combination. Besides reading and writing data strings, the VXI-11 Keyboard has controls for Device Clear, Device Trigger, and Serial Poll.

Easy Firmware Updates

The 8055 has a program download and store function which lets the 8055 receive program changes through its Ethernet interface. If a future firmware change is necessary, the new firmware and Upgrade Utility program

can be downloaded from ICS's website. The 8055 validates the new code before saving it in its Flash memory. The original factory code is never overwritten so the user can always revert back to the factory code.

Network Features

The 8055 uses the VXI-11 protocol or RPC over TCP/IP to communicate with the test program (client application). The TCP transportation layer and IP protocol guarantees error free communication with the 8055 over the network or Internet as long as the connection is maintained.

The 8055 has communication timeout and Keepalive capability to maintain the communication link with the client application. When the 8055 discovers that the channel is no longer active, or when a channel is closed, the 8055 closes that channel and releases all resources that were used by the client. This unlocks any instruments links, destroys the links and returns all resources to the pool for the next user.

8055 SPECIFICATIONS

Supported Standards

IEEE 488.1 Capabilities:

The 8055 meets IEEE-STD-488.1 with the following capabilities:

- AH1, SH1, C1, C2, C3, C4, and C9
- E2 Drivers incorporate power up/down protection.

Companion Instrument

Companion instrument must be IEEE-488.2 compatible. Supports only one instrument.

488 Bus Performance

Long term GPIB transfer rates are limited by the LAN data transfer rate, the Client-computer performance and the GPIB device. Short term 8055 data rates are:

GPIB to 8055	>180 kbyte/s
8055 to GPIB	> 180 kbytes/s
Supports	single instrument
Device Address	16addresses-a-singleprimary or dual consecutive primary addresses from 1-30 or a primary and up to 16 secondary addresses from 0100 to 3030.
Auto track	After configuration
8055 address	0 to 30 [0]

VXI-11 Capabilities

Fully VXI-11.3 compliant

VXI-11.3	Device Control
Clients	1 to 15
Channel types	Data, Abort and Interrupt
Instrument links	64 max
Locking	By instrument link

RPC Protocol

Conforms to ONC RPC Version 2

Ethernet Interface

Type	IEEE 802.3 compliant
Speeds	10BaseT (10 Mb/s) 100BaseT(100 Mb/s)
IP Address	Static or DHCP
Factory setting	192.168.0.254 static
Interface name	inst0-inst15 [inst0]

Internal WebServer

The internal WebServer provides HTML web pages for viewing and setting the 8055's network settings.

LabView is a trademark of National Instruments, Austin, TX.

VEE, IntuiLink and Benchlink are trademarks of Agilent Technologies, Palo Alto, CA.

The VXI-11 Specification is available from the VXI Consortium at <http://www.vxibus.org/specs.html> or from ICS's website at http://www.icselect.com/vxi_spec.html

System Requirements

Computer with an IEEE 802.3 LAN interface. Requires RPC support or a VXI-11 compliant VISA layer installed.

Supported Software

The 8055 supports the following application and program languages:

- NI LabVIEW (5.1 thru 8.5)
- Agilent VEE - IO Libraries 14.2 and later
- MathWorks MATLAB
- Visual Basic 6.0*
- Visual Basic .NET (2005)*
- Visual C, C++ and C#*
- Java*

* with VISA or RPC calls

Controls and Indicators

CONTROLS

Power	Front-panel switch
LAN Reset	Rear-panel push-button

LEDs

PWR	Power on
RDY	Unit has passed self test
LAN	Unit connected to an active LAN
ACT	Transferring messages to/from the network
TALK	Unit is addressed to talk
LSTN	Unit is addressed to listen
SRQ	SRQ asserted on GPIB bus
ERR	Unit has detected a soft error

Physical

Size 7.45" L x 5.57" W x 1.52" H
(18.92 cm L x 14.15 cm W x 3.86 cm H)

Weight 1.6 lbs. (0.73 kg.)
plus power adapter

Construction RoHS Compliant

Temperature
Operating -10 °C to +65 °C
Storage -40 °C to + 70 °C

Humidity 0-90% RH non-condensing

Shock/Vibration Normal handling

Connectors
GPIB GPIB 24 pin ribbon with metric studs.
Ethernet RJ-45

Power 9 to 32 Vdc @ 4 VA

RFI/EMI CE Certified

Included Accessories

Instruction Manual

CD-ROM with VXI-11 Keyboard Controller program and Configuration Utility.

LAN Crossover Cable.

UL/CSA/VDE approved AC power Adapters provided for:

- US - 115±10% Vac, 60 Hz (std.)
- E Europe - 230±10% Vac, 50/60 Hz
- B UK - 230±10% Vac, 60 Hz
- U Japan - 100±10% Vac, 50/60 Hz
- A Australia - 230±10% Vac, 60 Hz
- China - 230±10% Vac, 60 Hz

NOTE

For more information and programming examples refer to the AB80 series Applications Notes at www.icselect.com

ORDERING INFORMATION

Part Number

Ethernet - GPIB Controller with 115 VAC adapter, Manual and CD-ROM	8055
Ethernet - GPIB Controller with 230 VAC adapter, Manual and CD-ROM (Specify plug style) -E (Europe), -B (UK), -A (Australia)	
GPIB Accessory Cables	See separate data sheet
Rack Mounting Kits (holds one or two 8055s). See separate data sheet	Single - 114210, Dual - 114211