

RS-232/RS-485 SERIAL INTERFACES

2363 RS-232/RS-485 TO PARALLEL DIGITAL INTERFACE

DESCRIPTION

The ICS 2363 is a compact, RS-232/RS-485 to Parallel Interface that provides 48 programmable digital lines that can be configured as inputs or outputs in eight bit bytes. As inputs, each data line has a pullup resistor for sensing contact closures or TTL/CMOS inputs. As outputs, each line is latched and can source 24 mA or sink up to 48 mA. The 2363 can also be configured to monitor up to 15 input lines for changes. Applications include interfacing devices with parallel digital signals to a serial link, controlling discrete devices, and monitoring digital signals for changes.

All serial Mini-Box interfaces use SCPI commands for ease of programming and provide GPIB functionality over a serial link. The 2363 is packaged in a CE compliant metal case that is less than 1.6 inches (39 mm) high and 7.3 inches (186 mm) wide. Rack mounting kits are available for mounting one or two Model 2363s in a single 1U high space.

Versatile Digital Interface

The 2363's digital interface can be configured to match the user's application with commands from the serial interface. The configuration commands permit the user to designate the data lines as inputs and/or outputs in 8-bit byte increments, to connect the bytes into strings, set data polarity, data format, handshake modes and data format. The setup configuration is saved in the 2363's Flash memory and becomes the new power-on configuration.

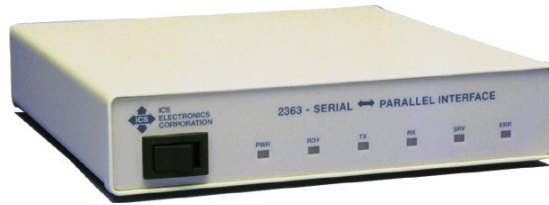

2363 Serial to Parallel Interface

Data Transfer Methods

Data transfer between the Serial Interface and the 2363's digital interface can be to or from specific bytes or as strings of values to or from one or more bytes. String transfers are done with data transfer commands. New bit operation commands set/reset specific bits in a byte and query a bit's status.

Outputting Data

Output byte commands specify a specific byte and the output data value(s). Data strobes are manually generated if needed. When outputting data as strings, the 2363 converts the string characters into packed HEX bytes, places the data in the configured output latches and generates a data strobe pulse to update the external device. The data strings can be a series of decimal values, ACSII HEX characters, or the 30-3F HEX characters used in the older Model 4833 series interfaces.

Input byte commands read data from a specific byte. When inputting data as strings, the 2363 reads the configured input bytes, converts the data to the selected output format, and outputs it as a string of characters. Data can be inputted with or without handshaking. The parallel input data can be formatted as decimal numbers, as ASCII HEX characters, or into any user selected character set.

New Bit Manipulation commands let the user directly set or reset an output bit and read an input bit.

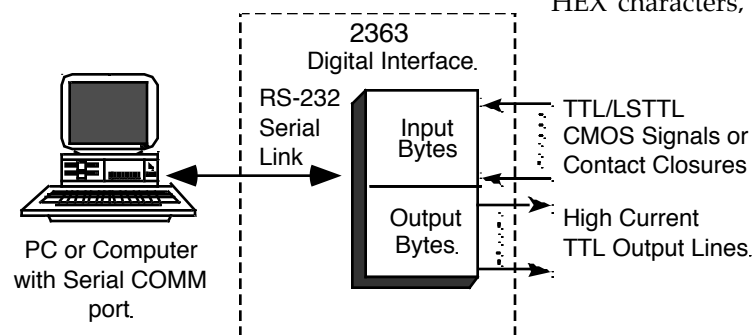

Figure 1 2363 Simplified Block Diagram

A flexible interface between a serial link and digital devices.

- Provides a user-definable parallel interface with with bit, byte, and string data transfer capabilities. *Fully configurable to the user's needs by bus commands.*
- Signal monitor feature detects signal changes. *Relieves controller of time consuming polling function.*
- High-current drivers and input pullup resistors. *Drives larger loads and inputs CMOS signals or contacts.*
- Programmable RS-232 and RS-485 serial interfaces. *Supports point-to-point or network connections*
- Provides IEEE-488.2 Status Structure and SCPI parser. *GPIB functionality over a serial link.*
- Device setup and network address stored in Flash. *Stored setup eliminates program initialization statements.*
- Includes a menu-driven configuration program. *Steps user through configuration choices.*

CE Approved

ICS ELECTRONICS
division of Systems West Inc.

7034 Commerce Circle
Pleasanton, CA 94588
Phone: 925.416.1000
Fax: 925.416.0105
Web: www.icselect.com

2363: Application

Input Signal Monitoring

The 2363 can monitor up to fifteen digital inputs for signal changes and generate a Service Request Message when the specified condition(s) occurs. Monitoring is accomplished by setting the 2363's Questionable transition registers to detect positive and/or negative signal transitions and enabling a bit in the event register. When the enabled condition is detected, the 2363 sends a Service Request Message to alert the Computer which can then query the 2363's Questionable condition or event register to determine the exact signal condition and change.

RS-232/RS-485 Interfaces

The 2363 provides both RS-232 and RS-485 signals on its 25-pin rear panel connector. The RS-232 interface is a full-duplex, three wire interface. The 2363's RS-485 interface is a two wire, half duplex interface for point-to-point or network connections.

Serial Address Detection

The Serial address detection capability enables the user to control up to sixteen 2363s on a single RS-485 network. When address recognition is enabled, the 2363 looks for an STX character and its address character before acting upon the command string. Separate commands set and enable the address detection functions.

Configuring the 2363

The 2363's configuration and data transfer commands are shown in Figure 2. Each function has a SCPI (Standard Commands for Programmable Instruments) command and some functions have Short Form commands for quick programming. Most of the functions can be queried to verify the command setting by adding a question mark to the command. i.e. CONF:INP? reads back the number of Input (Talk) bytes.

The SYSTEM branch sets the unit's serial parameters and enables the serial address function for RS-485 networks.

The CONFIGure branch assigns the bytes for string data transfer and sets their data polarity and handshaking. The CONFIGure branch also sets the control signal polarities.

The FORMat branch sets the data conversion method and the characters in the user's Talk conversion table.

The ROUTe branch provides the bit manipulation commands to directly set and reset individual bits.

The SENSE branch gives the user a way to directly read digital data from a single byte or from a list of the 2363's input bytes. When reading data from a specific byte, input data polarity can be assigned on a bit-by-bit basis.

The SOURCE branch provides a way to directly write values to a byte or to a list of bytes. When data is outputted to a specific byte, output data polarity can be assigned on a bit-by-bit basis.

The STATUS branch (not shown) is used to setup and query the Operational and Questionable registers so that changes in the digital inputs or status inputs can be used to generate 488 Service Requests (SRQs). The Questionable registers can be used to monitor and query 15 digital I/O lines.

Table 1 2363 SCPI Command Tree

SCPI Commands	Short Form Commands	
SYSTEM	Serial Configuration	
:COMM		
:SERial		
[:RECeive]		
:BAUD	<numeric value> [9600]	
:PARity	EVEN ODD [NONE]	
:BITS	7 [8]	
:SBITs	[1] 2	
:NETwork	[OFF] ON	
:ADDRess	0-15 [4]	
:UPdate		
:ERRor?	(0, "No error")	
:VERSion?	(1994.0)	
CONFigure	Setup	
[:DIGital]		
:INPut	<channel list>	N
:POLarity	0 1	TPn
:HANDshake	<boolean>	TBn
:OUTput	<channel list>	LN
:POLarity	0 1	LPn
:HANDshake	<boolean>	LH
:CLEar	0 1	C
:EDR	0 1	E
:INHibit		0 1 I
:REMote	0 1	R
:RESet	0 1	X
:STRobe	0 1	S
:TRIGger	0 1	TR
:ASTATus	0 1	A
:BSTATus	0 1	B
FORMat		
:TALK	<ASCIi Hex Table>	
:TRANSlation	<16 chars>	V
:LISTen	<ASCIi Hex 4833>	
ROUTe		Bit Commands
:CLOSe	byte, bit	CLOSE
:OPEN	byte, bit	OPEN
:RESEt	1-16	BRESET
SENSE		Port Input
[:DIGital]		
:DATA		
[:VALue]?	PI?	BI?
:PORT?	number or <channel list>	BIn?
:PORTn?		IPn
:POLarity?	0- 255	ER
:RESet:EDR		
[SOURCE]		Port Output
[:DIGital]		
:DATA		
[:VALue]	0-255	PO
:PORTn	0-255	BOn
:POLarity	0-255	OPn
:STRobe		SP
:BIT?	0-1	READ?
:BYTe?	0-255	BREAD?
CALibrate		Calibrate
:IDN	string 72 char max	
:DATE	mm/dd/yy or mm/dd/yyyy	
:DEFault		
:LOCK	1(On) 0(Off) [0]	

The CALibrate branch lets the user set his own IDN message and lockout the configuration settings to prevent accidental or unwanted changes.

OEM Board version

The 2363 is available as a board version for OEM applications. Board versions are designed to be mounted in the host's chassis and are powered from the host's 12 to 32 volt power supply. The boards are available with the interface configurations listed in Table 1. On the OEM boards, the interface headers are mounted vertically to minimize the board footprint. The Digital I/O connector is a right angle 62-pin connector with lock studs. A mating connector is included with each OEM board.

RS-232/RS-485 Interfaces

OEM board versions are equipped with RS-232 and RS-485 serial interfaces that can operate at rates up to 115,200 baud. The RS-485 interface has a terminating network that biases the serial lines in the mark state when they are not being driven. The serial interface is preset at 9600 baud, 8 data bits, and no parity. The serial interface provides all

of the functionality of the GPIB interface in the Model 2363 but allows control of the 2363 by any PC's COM port.

When the 2363 is connected at its RS-232 interface, the 2363 operates on a one-to-one basis with the controlling computer. When the 2363 connected at its RS-485 serial interface, the 2363 can operate on a one-to-one basis or it can be used in a RS-485 network. When the network function is enabled, the 2363 only responds to messages that are preceded by the correct address sequence. In ICS's 236x series products, the address sequence is a STX character followed by the address number.

The serial interface is on a 10-pin male header with pins on 0.1 inch centers. Use ICS's Serial Cable Kit to fabricate a cable to a 25-pin connector or to the serial source. Kit includes header plug, pins and a DB-25S connector.

LED Header

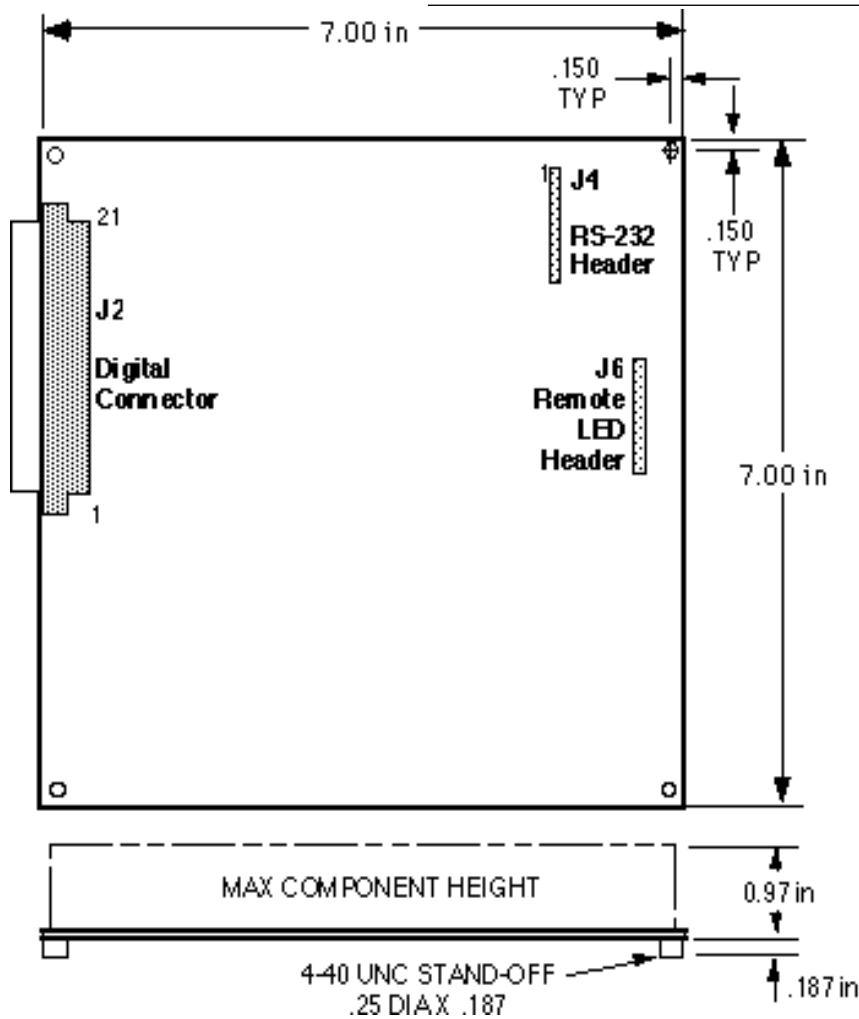

Figure 2 2363 OEM Board Dimensions

An 8 pin header on the OEM boards allows easy extension of the 2363's LEDs to the user's front panel.

OEM Customization

2363 firmware allows the user to store his IDN message and other setup parameters in the 2363's Flash memory. This effectively integrates the 2363 into the end product and makes the system appear as the OEM's product. A lock function hides these variables from the end user and prevents accidental changes to the setup.

Starter Kit

The OEM Starter Kit provides the OEM designer with everything a user needs to test and evaluate a 2363 OEM Board. The kit includes a 114504-05 Board, a serial cable for connecting to a PC COM port, and 2363 development software and an instruction manual. The software package includes a keyboard command line program, and a 2363 test program. Order the 2363 OEM Starter Kit as P/N 114719.

TABLE 2 OEM BOARD CONFIGURATIONS

Part Number	Interfaces		
	GPIB	RS-232	RS-485
114711	No	Yes	Yes

OEM 2363 Boards include Instruction Manual and configuration disk, mating digital connector and hood. Serial Cable Kit may be ordered separately.

2363: ORDERING GUIDE

Select the 2363 and then pick your accessory items.

Part Selection	Qty	Part Number
Standard 2363 Minibox with 48 I/O lines. Includes a 62-pin mating connector and hood	(1)	2363
<ul style="list-style-type: none"> — Select an extra mating digital I/O connector, 62-pin male - solder eyelet 	(1)	902270
<ul style="list-style-type: none"> — hood 	(1)	902105
<ul style="list-style-type: none"> — Select an Open end, 62 conductor, 28 AWG wire cable assembly, 5 feet long 	(1)	114508
<ul style="list-style-type: none"> or 		
<ul style="list-style-type: none"> — Select the Digital Extension Cable, pin-to-pin connections, male connectors (Dash number is cable length in feet) 	(1)	114714-003 (Note 1)
<ul style="list-style-type: none"> and 		
<ul style="list-style-type: none"> — Select mating female connector with right angle PCB tails 	(1)	902268
2363 OEM board with 48 I/O lines. Includes a 62-pin mating connector and hood	(1)	114711
<ul style="list-style-type: none"> — Select an extra mating digital I/O connector, 62-pin male - solder eyelet 	(1)	902270
<ul style="list-style-type: none"> — hood 	(1)	902105
<ul style="list-style-type: none"> — Select an Open end, 62 conductor, 28 AWG wire cable assembly, 5 feet long 	(1)	114508
<ul style="list-style-type: none"> or 		
<ul style="list-style-type: none"> — Select the Digital Extension Cable, pin-to-pin connections, male connectors (Dash number is cable length in feet) 	(1)	114714-003 (Note 1)
<ul style="list-style-type: none"> and 		
<ul style="list-style-type: none"> — Select mating female connector with right angle PCB tails 	(1)	902268
<ul style="list-style-type: none"> — Select a Serial Cable Kit with DB-25 rear panel connector 	(1)	114597

Notes:

1. The dash number is the cable length in feet.

2363: Specifications

Serial Interface

Provides RS-232 full duplex and RS-485 (RS-422) half duplex asynchronous serial interfaces. Unit automatically responds to the serial interface that receives the command.

RS-232 Interface

Signals: AB, BA and BB
Mode: Full Duplex

RS-485 (RS-422) Signals

Signals: TX/RX pair
Mode: Half duplex with or without address detection
Addresses: 0 to 15
Termination: 220 ohm load resistor and 1 K Ω pullup/pulldown resistors.

Data Rates and Formats

Baud Rate: 1200 to 115.2 Kbaud
Data bits: 7 or 8
Stop bits: 1 or 2
Parity: Odd, Even or Nonee

Command Sets

SCPI and short form commands listed in Tables 1 plus the following IEEE 488.2 Common Commands:

*CLS, *ESE, *ESE?, *ESR?, *IDN?, *OPC, *OPC?, *PSC, *PSC?, *RCL, *RST, *SAV, *SRE, *SRE?, *TRG, *TST, and *WAI.



Figure 3 2363 with Included Accessories

Signal Characteristics

The 2363's parallel I/O signals have the following electrical characteristics. All time delays listed here are maximums, all pulse widths are minimums.

Lines 48 Digital I/O plus
2 Status Inputs
Input Logic Levels High = $> +2.0$ V @ ± 10 μ A
Low = < 0.8 V @ 250 μ A
with 33 Kohm pullup to +5 Vdc for sensing contacts.
Max High = 5.5 V

Input Timing External Data Inhibit line SETS within 1 μ s of the active edge of the EDR Input signal and resets after data is loaded. Data loading time for 6 BCD/HEX characters is 0.15 ms (typ.) after the 2363 has been addressed as a Talker

Output Logic Levels High = > 3 V with 3 mA source
High = > 2 V with 24 mA source
Low = 0.0 to +0.55 Vdc, 48 mA sink

Output Timing Data is transferred to the output 0.7 to 6 ms after receipt of a terminator depending upon transfer method.

Data Stb Trigger Clear Reset Output pulse width, 7 μ s
Output pulse width, 7 μ s
Output pulse width, 7 μ s
Output pulse width, 50 μ s for *RST command and true during 2363 reset time (70 ms)

Controls and Indicators

POWER Front-panel switch energizes unit
PWR Indicates power on
RDY Unit has passed self test
TX Unit is transmitting
RX Unit is receiving
SRV Unit sent Service Request Msg
ERR Unit has detected a command error

Physical

Size W x H x D
7.29 x 1.52 x 7.45 inches
(1185.2 x 38.6 x 189.2 mm)

Weight 3 lbs (1.4 kg)

Temperature
-10°C to +55°C Operating
-40°C to +70°C Storage

Humidity 0-90% RH no condensation

Construction All metal case shields RFI

Connectors and Headers

Serial: 25-pin female, metal DB shell w/lock studs
I/O: 62-pin female, metal DC shell connector with lock studs
Serial Header: 10-pin male
LED Header: 8-pin male

Power 9 to 32 Vdc @ 3 VA

Included Accessories

Instruction Manual
3.5 in Configuration Program Disk.
UL/CSA/VDE/CE approved AC power adapters provided for:
US - 115 \pm 10% Vac, 60 Hz (std)
Europe - 230 \pm 10% Vac, 50/60 Hz
UK - 230 \pm 10% Vac, 60 Hz
Japan - 100 \pm 10% Vac, 50/60 Hz
Mating 62-pin connector and hood

ORDERING INFORMATION

Part Number

Serial <-> Parallel Digital Interface with 115 VAC adapter 2363

Serial <-> Bus Parallel Digital Interface with 230 VAC adapter. Specify plug style: -E (Europe), -B (UK), -A (Australia)

OEM Board version of the Serial <-> Parallel Digital Interface (Does not include a power adapter) 114711

Serial cable kit for OEM boards 114597